

# GROUND IMPROVEMENT TECHNIQUES

## UNIT-I

### Objective:

To understand the need of ground improvement techniques

To know about the different techniques involved in densifying the soils

### Syllabus: INTRODUCTION

Need and objectives of Ground Improvement techniques, Classification of ground modification techniques, Suitability and feasibility

Methods of compaction-Shallow Compaction, Deep Compaction

Shallow Compaction: Smooth wheeled Rollers, Sheep foot rollers, Pneumatic tired rollers

Deep Compaction: Vibroflotation, Blasting, Dynamic consolidation, Precompression and Compaction Piles

### Learning Outcomes:

After completion of this unit the student will be able to

- Explain the need and objective of ground improvement techniques
- List the different techniques that are available for improvement
- Choose the suitable technique depending upon the condition of soil and requirements
- Know different methods that are available for Compaction or densifying the soils
- Identify the type of techniques required for various soils

## LEARNING MATERIAL

### 1.1 Need for Ground Improvement:

Generally Engineers design Foundation and other structures basing on soil investigation. If soil good at lesser depth shallow foundation can be laid, if hard stratum available at higher depth, Deep foundation can be laid.

In some cases, Deep foundation becomes uneconomical, it becomes a problem practically. So there need arises to improve the ground conditions by ground improvement. However, it is also costly but proved to be cost effective many times.

*Ground improvement is rapidly developing field because good sites for construction are limited day by day. So improving characteristics of soil at site, that consists of increasing shear strength, decreasing compressibility of soil. So that Bearing capacity increases which reduces settlements.*

As more and more land becomes subject to urban or industrial development, good construction sites and borrow areas are difficult to find and the soil improvement alternatives becomes the best option, technically and economically.

Where a project encounters difficult foundation conditions, possible alternative solutions are:

1. Avoid the particular site: Relocate a planned highway or development site.
2. Design the planned structure accordingly: Some of the many possible approaches are to:
  - Use a raft foundation supported by piles,
  - Design a very stiff structure which is not damaged by settlement,
  - Or choose a very flexible construction which accommodates differential movement or allows for compensation.
3. Remove and replace unsuitable soils: Remove organic topsoil, which is soft, compressible, and volumetrically unstable. This is a standard precaution in road or foundation construction.
4. Attempt to modify the existing ground

## 1.2 Objective of Ground Improvement Techniques

The most common traditional objectives include improvement of the soil and ground for use as a foundation or construction material.

The typical Engineering objectives have been:

- 1) Increasing shear strength, durability, stiffness and stability
- 2) Reducing undesirable properties (eg. Shrink/ swell potential, compressibility, liquefability)
- 3) Modifying permeability, the rate of fluid to flow through a medium; and
- 4) Improving efficiency and productivity by using methods that save time and expense

The engineer must take a determination on how best to achieve the desired goals required by providing a workable solution for each project encountered. Ground improvement methods have provided adverse choice of approaches to solving these challenges.

## 1.3 Factors affecting choice of improvement method

1. **Soil type:** This is one of the most important parameters that will control what approach or materials will be applicable to only certain types of soil types and grain sizes
2. **Depth and location of treatment required-** many ground improvement methods have depth limitations that render them unsuitable for applications for deeper soil horizons.
3. **Desired/required soil properties-** obviously, different methods are use to achieve different engineering properties, and certain methods will provide various levels of uniformity to improved sites.
4. **Availability of materials-** Depending on the location of the project and materials required for each feasible ground improvements approach.
5. **Availability of skills, local experience, and local preferences-** While the engineer may possess the knowledge and understanding of a preferred method.
6. **Environmental concerns-** With a better understanding and a greater awareness of effects on the natural environment, more attention have been placed on methods that assure less

environmental impacts.

7. **Economics**- when all else has been considered, the final decision on choice of improvement method will often come down to the ultimate cost of a proposed method, or cost will be the deciding factor in choosing between two or more otherwise suitable methods.

#### **1.4 Classification of Ground Modification Techniques**

Four groups of ground improvement Techniques are distinguished:

1. Mechanical modification
2. Hydraulic modification
3. Physical and chemical modification
4. Modification by inclusion and Confinement

##### **a. Mechanical modification**

Soil density is increased by the application of short-term external mechanical forces, including Compaction of surface layers by:

- Static,
- Vibratory,
- Impact rollers,
- Plate vibrators.

Deep compaction by heavy tamping at the surface or vibration at depth

##### **b. Hydraulic modification**

Free –pore water is forced out of the soil via (by means of) drains or wells. - In coarse grained soils, this is achieved by lowering the ground water level through pumping from boreholes or trenches. - In fine-grained soils, the long term application of external loads (preloading) or electrical forces (electro kinetic stabilization) is required.

##### **c. Physical and chemical modification**

Additives include: - natural soils - industrial by-products or waste materials (fly ash, slag), - Cementations and other chemicals (lime, cement) which react with each other and the ground. When additives are injected via boreholes under pressure into the voids within the ground or between it and a structure, the process is called GROUTING. Rigs with multiple injectors deliver the stabilizing fluid into the soil. The fluid will prefer to travel into cracks and fissures.

Soil stabilization by heating the ground and by freezing the ground come under, Thermal Methods of Modification.

- Heating evaporates water and causes permanent changes in the mineral structure of soils.
- Freezing solidifies part or all of the water and bonds individual particles together.

##### **d. Modification by inclusion and Confinement Reinforcement by:**

- Fibers, Strips, Bars, Meshes and Fabrics.

In-situ reinforcement is achieved by nails and anchors.

### **1.5 Suitability and Feasibility**

The choice of a method of ground improvement depends on many factors including:

- Type and degree of improvement required
- Type of soil, geological structure,
- Seepage conditions,
- Cost (the size of the project may be Decisive),
- Availability of equipment and materials and the quantity of work required,
- Construction time available,
- Possible damage to adjacent structures or Pollution of ground water resources,
- Durability of the materials involved,
- Toxicity or corrosively of any chemical Additives

The feasibility of a particular method is strongly related to the type of problem in hand:

- A foundation,
- An embankment on soft ground,
- An unstable slope,
- An excavation,
- An earth-retaining structure,
- A leaking dam or reservoir.

### **1.6 Improvement of cohesive soils:**

Cohesive soils such as soft clay with large void ratio and higher water content have a necessity to improve their characteristics. To reduce void ratio and water content, to increase strength for which increases bearing capacity of soil.

Generally following methods are in practice:

1. Precompression or Preloading
2. Sand Drains
3. Wick Drains
4. Stone columns

### **1.7 Improvement of cohesion-less soils:**

Cohesion-less soils with  $N < 10$  value has low shear strength, and hence the bearing capacity is quite low. If a deposit of loose sand exists at site of construction the ground improvement can be achieved by strong vibration in ground. Such that relative density increases, consequently N- Value and Bearing capacity increases.

Some of the adopted methods are:

1. Vibrofloatation
2. Terra Probe
3. Dynamic Impact
4. Compaction by Blasts
5. Compaction Piles

Mechanical stabilization covers two methods of changing soil properties,

- i) The rearrangement of soil particles and
- ii) The improvement of soil gradation.

There are several examples of particle rearrangement i.e., the blending of the layers of a stratified soil, the remoulding of an undisturbed soil, and of most importance, the densification of soil. Methods of densification of soils are of two types.

1. Surface/shallow Compaction
2. Deep Compaction

## **SURFACE/SHALLOW COMPACTION**

Shallow compaction is achieved either by static pressure or dynamic pressure is caused by impact or vibration. The rollers used for static pressure and the impact on the surface can be caused by various equipments are as follows:

**Static Rollers:** Smooth Wheeled Rollers, Pneumatic tired rollers, Sheep foot rollers and Grid Rollers

**Impact or vibratory Equipment:** Heavy Tampers and impact rollers.

**Smooth wheel rollers:**

These are two types. One with two large wheels in rear and smaller single drum in front and the other type has large single drum in the front and the rear.

These might be static and Vibratory type.

Static type:

- Gives limited pressure because of their relatively large contact area.
- Effective depth of Compaction is limited to shallow.
- Compaction is restricted only for thin layers
- Compaction is done in separate layers. Eg. Base, Sub-base, Sub-grade layers.

Some rollers are equipped with electronic devices named by compaction meters, which receives continuous signals from accelerometer mounted on drums, measures deformation modulus and moisture content of soil through correlation.

Vibratory type:

These have a light impact effect on the ground. The vibrating amplitude of this roller varies in the order of 1-2mm. Heavy vibrating drums are fixed to the rollers to add the impact on the ground. Compaction mainly depends on static weight, frequency and amplitude, speed of roller, Drum diameter.

- Effective in compacting clean granular soils in fills or subgrades.
- Maximum compaction effort in soils is achieved at frequency between 25 and 50Hz with amplitude in the range of 1.5 to 2.0mm.
- Normal rollers speed ranges between 3 and 6 km/hr.

### **Sheep foot rollers:**

Well suited for compacting clay and silty-clay soils. Sheep foot rollers are also called as tamping foot rollers, have projecting studs or feet on the surface of the rollers and compact by a combination of tamping and kneading action. The kneading action of the feet causes successive layers to be fused and thus increases the stability.



These compactors consist of steel drums which can be filled with water or sand to increase the weight. As rolling proceeds, most of the roller weight is imposed through the projecting studs and results in fairly high contact pressure.

When a loose soil layer is initially rolled, the projections sink into the layer and compact the soil near the lowest portion of the layers. In subsequent passes, the zone being compacted already continuously rises until the surface is reached.

These rollers are available in drum width ranging from 120 to 180cm and drum diameter

ranging from 100 to 180cm and load per drum ranges from 2950 to 13600 kg. The area of foot ranges from 36 to 50 sq cm and length range from 18 to 25.5 cm.

Rollers are available in two types. 1. Self propelled. 2. Only rollers (A tractor is required to tow the rollers where self propelled rollers attain speed of 9km/hr).

Advantages:

- More suitable for cohesive soils.
- Feet or stud produces kneading action.
- Possible soil compaction over a wide range of moisture content.
- Effective in breaking large pieces of soft rock.

Disadvantages:

- Relatively slow operation
- Lower compacted density
- Large entrapped air

### **Pneumatic Tired Rollers:**

These rollers are more effective for low cohesive soils and cohesionless soils like Gravels, Sands, Clayey soils, silty sands and even sandy clays.

- In this technique compaction is due to kneading action.
- These rollers are outfitted with a weight box between two axles so that the compaction load can be easily varied. Light rubber tired roller have 7 to 13 wheels which are mounted in two rows.
- The wheels fitted on the rear row are such that fitted in the tracks of the spaces between of the front row wheels.
- These rollers are available in wide range of loads, of which the heaviest is 1800kN. However 450kN is in common use.
- Roller speeds generally vary between 6 to 12 Km/hr. Heavier weight rollers requires less number of passes and gives smooth finishing compared to smooth wheeled rollers
- Light rollers (20000Kg) compacts 15cm thick with few passes where as in heavy rollers (40000kg to 50000kg) compacts 30cm thick layer with 3-5 passes only.
  - ✓ Wheel load
  - ✓ Tire Sizes
  - ✓ Inflation Pressure depends upon the soil type and equipment available
  - ✓ No. of passes
  - ✓ Loose Lift thickness

**Grid Rollers:**

- These are intermediate of smooth wheeled and sheep foot rollers. With their rotating wheels made of a network of steel bars forming a grid with square holes.
- These rollers provide less kneading action but high contact pressure.
- Mostly suitable for coarse grained soils.

**Impact rollers:** These consist of a non circular mass, which can be pulled on the ground. It results in high impact effect i.e., heavy compaction is carried out as its center rises and falls and leaves an uneven surface.

**DEEP COMPACTION**

The following are the techniques applied in densification of deep soil deposits.

1. Pre-compression: In this technique, the site is preloaded or precompressed by the application of surcharge load on the surface. This technique is adopted for cohesive soils.
2. Explosion or Blasting: In this technique a certain amount of explosive charge is buried at a certain depth of cohesionless soil required to be compacted and then detonated.
3. Heavy tamping: This technique is also called as dynamic consolidation. This technique basically utilizes the vibration and shocks caused by dropping an heavy weight and then densification takes place by displacement of soil grains.
4. Vibration: Soil Densification in this technique is obtained by vibrating the piles or the needles inserted in to the ground surface.
5. Compaction Grouting: This technique is applied with very stiff mortar and is injected to loose soils where there is a possibility to form a grout bulb. Grout bulb makes the surrounding soil densified and displaces without any penetration in to the soil pores.

**BLASTING:**

In this technique a certain amount of explosive charge is buried at a certain depth of cohesionless soil required to be compacted and then detonated.

A Borehole is made and a pipe of 7.5 to 10cm is driven to the required depth of the soil.

Then the sticks of dynamite and a electric detonator are wrapped in the water proof bundles and lowered down through the casing. The casing is withdrawn and a wad of paper or wood is placed against the charge of explosives to protect it from misfire.

The hole is backfilled with sand in order to obtain the full force of blast. The electric circuit is



closed to fire the charge.

In this manner a series of holes are made ready. Each hole is detonated in succession and the resulting large diameter holes are formed by lateral displacement are back filled.

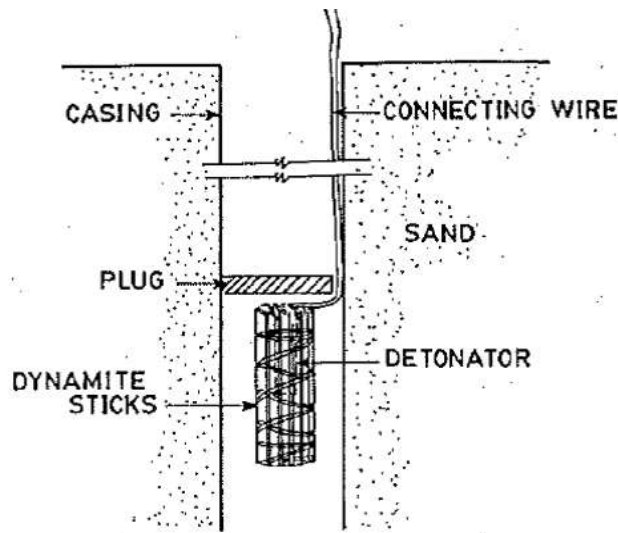

Usually Explosions are arranged in the form of horizontal grid of which spacing is depended on the depth of strata to be densified, the size of the charge and the overlapping of the charges. Generally a spacing of 3-8m is used and should not be less than 3m.

Weight of charge required can be computed from the following relationship,

Where  $W$  = weight of the explosive (N)

$C$  = Coefficient (0.0025 for 60% detonator)

$R$  = Radius of influence (m).

Generally, a charge mass of 2kg to 30kg are to be used.

A typical pattern of firing the explosions are as follows

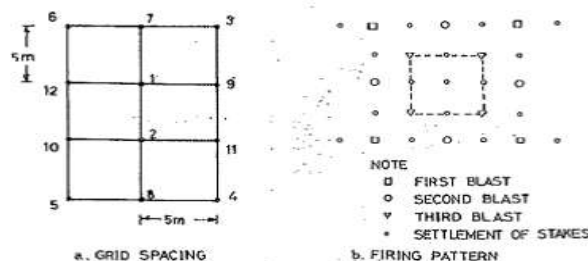

However, adequate data regarding to the following are to be collected before planning this kind of technique.

- Type of soil
- Depth of compaction

- Degree of saturation
- Degree of densification

Sometimes some preliminary tests are required to ascertain spacing, depth, sequence of operation.

**Advantages:**

- ✓ This technique requires less time, less labour, less expensive
- ✓ More successful for greater depth
- ✓ Large volume compaction.

**Disadvantages:**

- ✓ It requires experienced person and special supervision
- ✓ Non uniformity
- ✓ Adverse affects on adjacent structures.
- ✓ Only suitable when the soil is in dry or completely saturated.
- ✓ Very fine grained soils with cohesion cannot be compacted.

**COMPACTION PILES**

This method consists of driving a hollow steel pipe with a detachable bottom plate down to the desired depth. The driving can be done either by using an impact hammer or a vibratory driver. Sand is introduced in lifts with each lift compacted concurrently with a withdrawl of the pipe pile. Compressed air is blown down inside the casing to hold the sand in place. The in-situ soil is densified while the pipe is being driven down. The compacted sand pile prevents collapsing of the surrounding soil as the pipe is withdrawn. During the process of compaction, the compacted column expands laterally below the pipe tip forming a caisson pile. This technique is also referred to as vibro-composer method. The installation process is schematically shown in figure below.

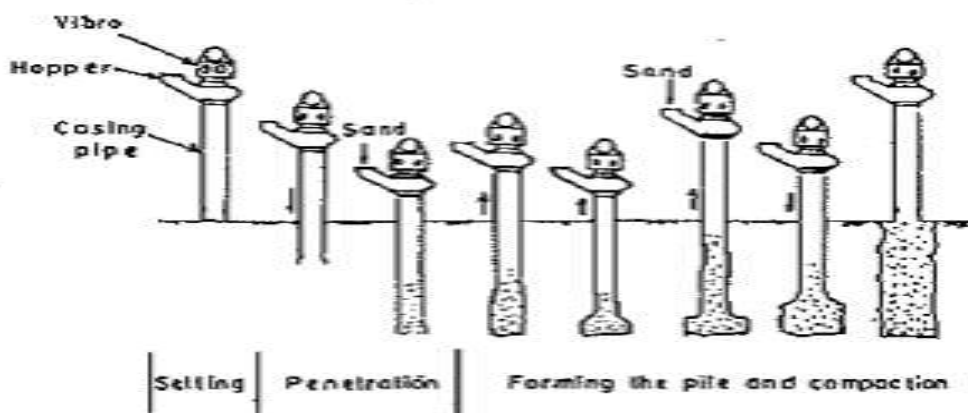

This method is economical for moderate depths upto 15m. Although this technique is costlier for deeper depths compared to other vibration methods, the treated ground generally has uniform properties.

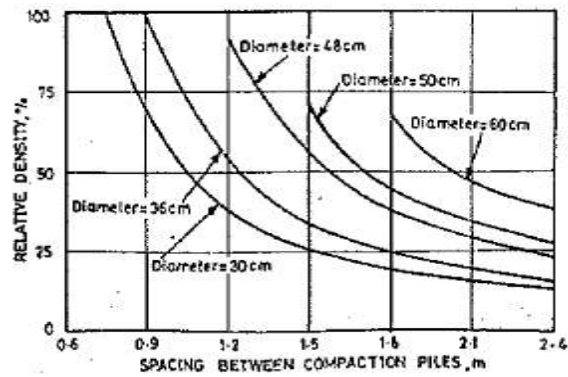

If the initial void ratio is  $e_0$ , at which after compaction the final void ratio is given by  $e$  and the pile spacing  $S$  may be obtained from

Where  $d$  is diameter of the pile.

### VIBROFLOTATION

- Efficient technique for densifying the cohesionless soils.

This technique was originated in Russia and was applied in Germany in 1939 for improvement of building foundation soils.

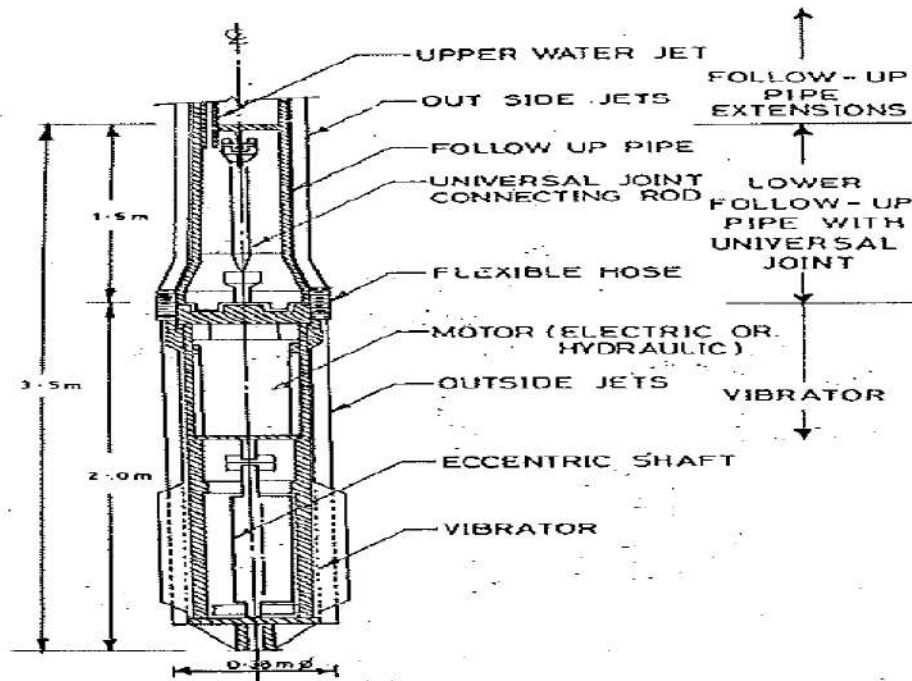

Equipment of comprises of

- Vibrofloat Probe
- Accompanying power supply
- Water supply
- Crane
- Front end loader (used for backfilling soil)

Vibrofloat Probe: It consists of cylinder with 400mm dia and 2m long, with a motor and an eccentric shaft to create centrifugal forces of 100kN at 1800rpm.

The equipment primarily is of two parts

- i. Lower part which is an horizontal vibrating unit which connects to the upper part
- ii. Upper part, it is a followup pipe in which length can be varied depending up on compaction depth.

Once the equipment is dropped or freely suspended to the compaction required depth. It has four basic steps to complete a compaction sequence as follows

- Vibro float is positioned over the spot to be compacted and its lower jet is then fully opened.
- Water is pumped in faster than it can be drained in to sub soil. This creates momentary quick condition beneath the jet.
- Water is switched from the lower to the top jets and the pressure is reduced to allow water to return back to the surface and facilitating continuous feed of backfill.
- Compaction takes place during 0.3m per minute lift on which the vibro float returns to the surface.

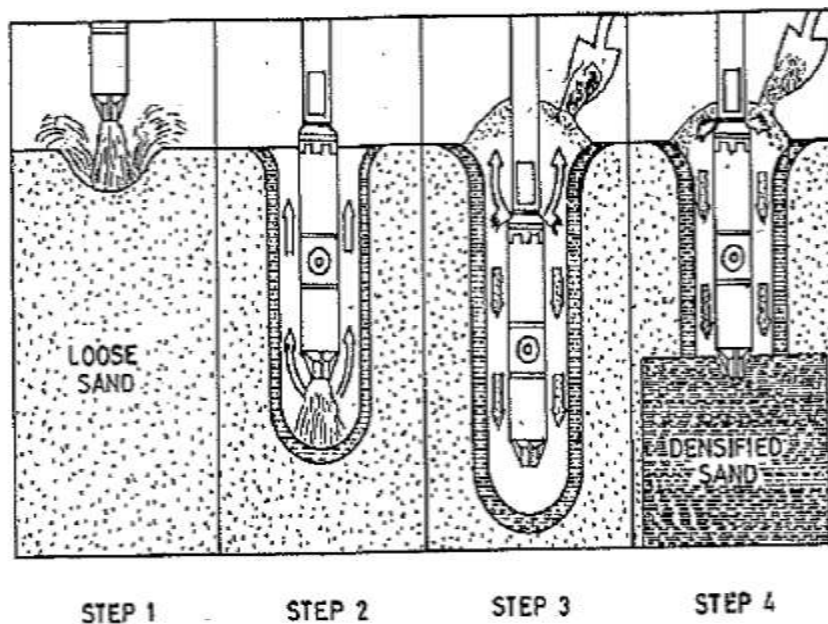

Liquefaction occurs at a radial distance of 300 – 500mm distance from the surface of the vibro float. In each filling of backfill it consumes 0.5 to 1.5m<sup>3</sup> of soil per meter depth.

Application of this technique depends on the following factors:

- Equipment capacity
- Probe spacing and pattern
- Type of soil to be compacted
- Backfill material

- Vibro float withdrawal procedure (Generally 0.3 – 0.6m/minute is a customary)
- Workman ship

**Backfill material:**

Generally depends upon the gradation of soil. Brown (1976) had given a rating system to assess the suitability of backfill material.

Suitability Number= where are particle sizes corresponding to 10%, 20% and 50% finer from the gradation curve.

Suitability Number	Description of rating
0 to 10	Excellent
10 to 20	Good
20 to 30	Fair
30 to 50	Poor
> 50	Unsuitable

This technique claims its *merits* based on the following:

- ✓ No Material cost except backfill material
- ✓ Complete uniformity in density therefore better control of settlements
- ✓ Gives high bearing capacity (250 – 400 kPa)
- ✓ Faster than pile driving
- ✓ Much quicker in operation than conventional impact hammer

**DYNAMIC COMPACTION OR DYNAMIC CONSOLIDATION**

Dynamic compaction is also known as heavy tamping. A technique which uses an heavy hammer of weight up to 45000kg and will be dropped freely from a height of 15 to 20m to the ground surface.

The heavy impact causes its mark on the ground surface and creates vibrations in adjacent soils. This process is repeated at same location over the subsequent parts of the area with spacing 5 to 10m.

Usual energy per blow is  $135 \times 10^3$  –  $450 \times 10^3$  kg-m. Generally 2 to 3 blows per square meter is used.

When the weight strikes the ground surface vibrations pass through the adjacent soil layers in the form of P, S and R waves.



Considering effective depth as a function of impact energy the depth of penetration is within the following range

D is effective depth (m)

W is weight of drop (kg)

h is height of drop (m)

Merits:

- One of the simplest methods for compacting loose soils
- Depth of compaction can reach upto 20m
- Any type of soil can be compacted
- Produces equal settlements throughout the area

This method depends upon the following

- i. Magnitude of the weight
- ii. Size of the weight
- iii. Height of the drop
- iv. No. of drops
- v. Distribution of drops throughout the site
- vi. Homogeneity of soil throughout the site
- vii. Strength & permeability of soil
- viii. Degree of saturation (Water Content)

## UNIT – II

### HYDRAULIC STABILIZATION

**Objective:** To know about the different techniques involved in dewatering to make an strengthen for constructions and other works.

**Syllabus: Methods of dewatering-** Open sumps and ditches, well point system Electro-osmosis, Vacuum dewatering wells, Preloading with sand drains, Strip drains, Design of vertical drains

**Outcomes:**

Student will be able to

- Know different methods that are available for dewatering
- Idealize the working procedure involved in the methods
- Know about different kinds of drains that are able to make the site free from water logging

#### **LEARNING MATERIAL**

Construction of buildings, powerhouses, dams, locks and many other structures requires excavation below the water table into water-bearing soils. Such excavations require lowering the water table below the slopes and bottom of the excavation to prevent ravelling or sloughing of the slope and to ensure dry, firm working conditions for construction operations. Groundwater can be controlled by means of one or more types of dewatering systems appropriate to the size and depth of the excavation, geological conditions, and characteristics of the soil.

Construction sites are dewatered for the following purposes:

- To provide suitable working surface of the bottom of the excavation
- To stabilize the banks of the excavation thus avoiding the hazards of slides and sloughing
- To prevent disturbance of the soil at the bottom of excavation caused by boils or piping, such disturbances may reduce the bearing power of the soil.

A number of methods are available for controlling the inflow of water into an excavation; the choice of method will depend on the nature and permeability of the ground, the extent of the area to be dewatered, the depth of the water table below ground level and the amount by which it has to be lowered, the proposed methods of excavation and ground support, the proximity of existing structures, the proximity of water courses etc.

The available methods of groundwater control fall into the following basic groups:

1. Surface water control like ditches, training walls, open excavations, embankments.
2. Gravity drainage. Relatively impermeable soils.

3. Sump pumping
4. Well-point systems with suction pumps.
5. Shallow (bored) wells with pumps.
6. Deep (bored) wells with pumps.
7. Eductor system
8. Drainage galleries. Removal of large quantities of water for dam abutments, cut-offs, landslides etc. Large quantities of water can be drained into gallery (small diameter tunnel) and disposed of by conventional large – scale pumps.
9. Electro-osmosis. Used in low permeability soils (silts, silty clays, some peats) when no other method is suitable. Direct current electricity is applied from anodes (steel rods) to cathodes (well-points, i.e. small diameter filter wells)

### **Sumps and sump pumping:**

A sump is merely a hole in the ground from which water is being pumped for the purpose of removing water from the adjoining area. They are used with ditches leading to them in large excavations. Up to maximum of 8m below pump installation level; for greater depths a submersible pump is required. Shallow slopes may be required for unsupported excavations in silts and fine sands. Gravels and coarse sands are more suitable. Fines may be easily removed from ground and soils containing large percent of fines are not suitable. If there are existing foundations in the vicinity pumping may cause settlement of these foundations. Subsidence of adjacent ground and sloughing of the lower part of a slope (sloped pits) may occur. The sump should be preferably lined with a filter material which has grain size gradations in compatible with the filter rules. For prolonged pumping the sump should be prepared by first driving sheeting around the sump area for the full depth of the sump and installing a cage inside the sump made of wire mesh with internal strutting or a perforating pipe filling the filter material in the space outside the cage and at the bottom of the cage and withdrawing the sheeting.

### **Well point systems:**

A well-point is 5.0-7.5 cm diameter metal or plastic pipe 60 cm – 120 cm long which is perforated and covered with a screen. The lower end of the pipe has a driving head with water holes for jetting. Well-points are connected to 5.0-7.5 cm diameter pipes known as riser pipes and are inserted into the ground by driving or jetting. The upper ends of the riser pipes lead to a header pipe which, in turn, connected to a pump. The ground water is drawn by the pump into the well-points through the header pipe and discharged. The well-points are usually installed with 0.75m – 3m spacing (See Table 1). This type of dewatering system is effective



in soils constituted primarily of sand fraction or other soil containing seams of such materials. In gravels spacing required may be too close and impracticable. In clays it is also not used because it is too slow. In silts and silt – clay mixtures the use of well points are aided by upper (0.60m – 0.90m long) compacted clay seals and sand-filtered boreholes (20cm – 60cm diameter). Upper clay seals help to maintain higher suction (vacuum) pressures and sand filters increase the amount of discharge. Filtered boreholes are also functional in layered soil profiles.

The header pipe (15-30 cm diameter, connecting all well-points) is connected to a vacuum (Suction assisted self – priming centrifugal or piston) pump. The well-points can lower a water level to a maximum of 5.5 m below the center line of the header pipe. In silty fine sands this limit is 3 – 4m. Multiple stage system of well-points are used for lowering water level to a greater depth. Two or more tiers (stages) are used. More pumps are needed and due to the berms required the excavation width becomes wider. A single well-point handles between 4 and 0.6m<sup>3</sup>/hr depending on the soil type. For a 120 m length (40 at 3 m centres) flow is therefore between 160 and 24 m<sup>3</sup>/hr.

Horizontal well-points are used mainly for pipeline water. They consist of perforated pipes laid horizontally in a trench and connected to a suitable pump.

Following is the list of factors to be collected:

1. The physical Layout
2. Adjacent areas
3. Soil conditions
4. Permeability of soil
5. The amount of water to be pumped
6. Depth to imperviousness
7. Stratification

#### **Advantages of Well point system**

- a) Installation is very rapid
- b) Requires reasonably simple and less costly equipment
- c) Water is filtered and carries little or no soil particles
- d) There is less danger of subsidence of the surrounding ground than with open sump pumping.

#### **Limitations of Well Point systems:**

1. A Lowering of about 6m (20ft) below pump level is generally possible beyond which

excessive air shall be drawn into the system through the joints in the joints, pipes, valves etc., resulting in the loss of pumping efficiency.

2. If the ground is consisting mainly of large gravel, stiff clay or soil containing cobbles or boulders it is not possible to install well points.

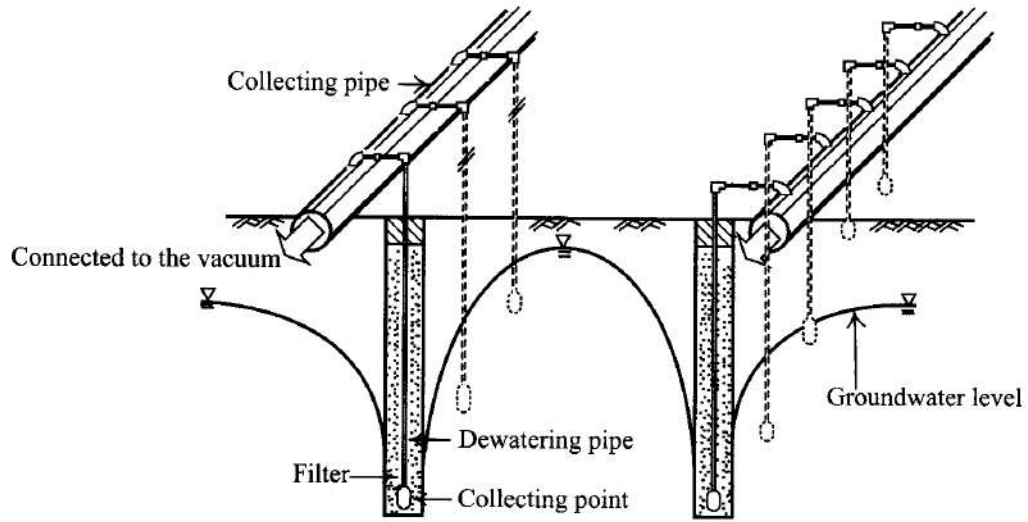

**General View of Well Point System**

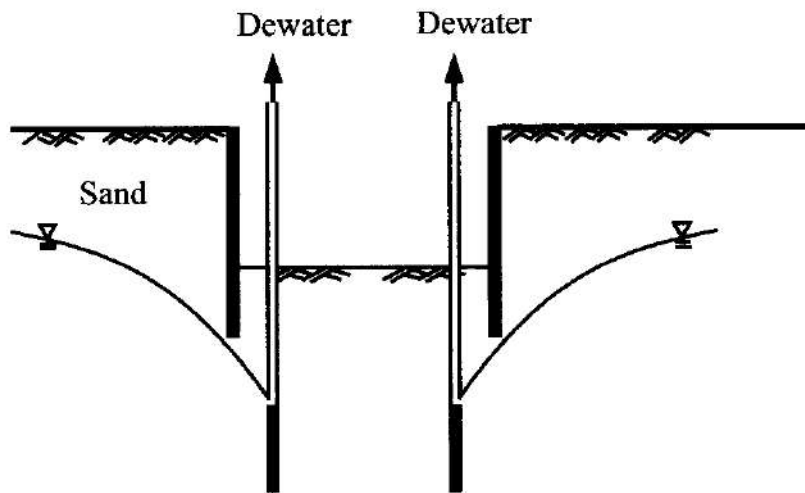

**Single Stage Well Point System**

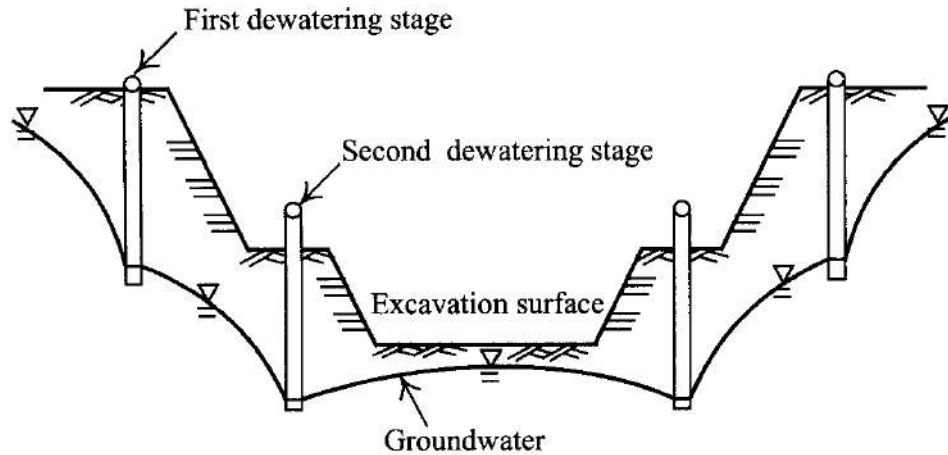

**Two Stage Well Point Systems**

### **Shallow Wells:**

Shallow wells comprise surface pumps which draw water through suction pipes installed in bored wells drilled by the most appropriate well drilling and or bored piling equipment. The limiting depth to which this method is employed is about 8 m. Because wells are pre-bored, this method is used when hard or variable soil conditions preclude the use of a well-point system. These wells are used in very permeable soils when well-pointing would be expensive and often at inconveniently close centres. The shallow well can be used to extract large quantities of water from a single hole. On congested sites use of smaller number dewatering points is preferred (no hinderance to construction operations) hence shallow wells may be preferred to well-points. Since the initial cost of installation is more compared to well-points it is preferred in cases where dewatering lasts several months or more. Another field of application is the silty soils where correct filtering is important.

### **Deep Wells:**

When water has to be extracted from depths greater than 8 m and it is not feasible to lower the type of pump and suction piping used in shallow wells to gain a few extra meters of depth the deep wells are such and submersible pumps installed within them. A cased borehole can be sunk using well drilling or bored piling rigs to a depth lower than the required dewatered level. The diameter will be 150 – 200 mm larger than the well inner casing, which in turn is sized to accept the submersible pump. The inner well casing has a perforated screen over the depth requiring dewatering and terminates below in 1 m of un-perforated pipe which may serve as a sump for any material which passes the filter. After the slotted PVC or metal well screen (casing) has been installed it is surrounded by backfill over the un-perforated pipe length and with graded filter material over the perforated length as the outer casing

progressively withdrawn.

Deep well systems are of use in gravels to silty fine sands and in water bearing rocks. They are priority or use with deep excavations and where artesian water is present below an impermeable stratum. If this type of installation is to be designed economically the ground permeability must be assessed from full scale pumping tests. Because of their depth and the usually longer pumping period these installations are more likely to cause settlement of nearby structures, and the use of recharge methods may have to be considered.

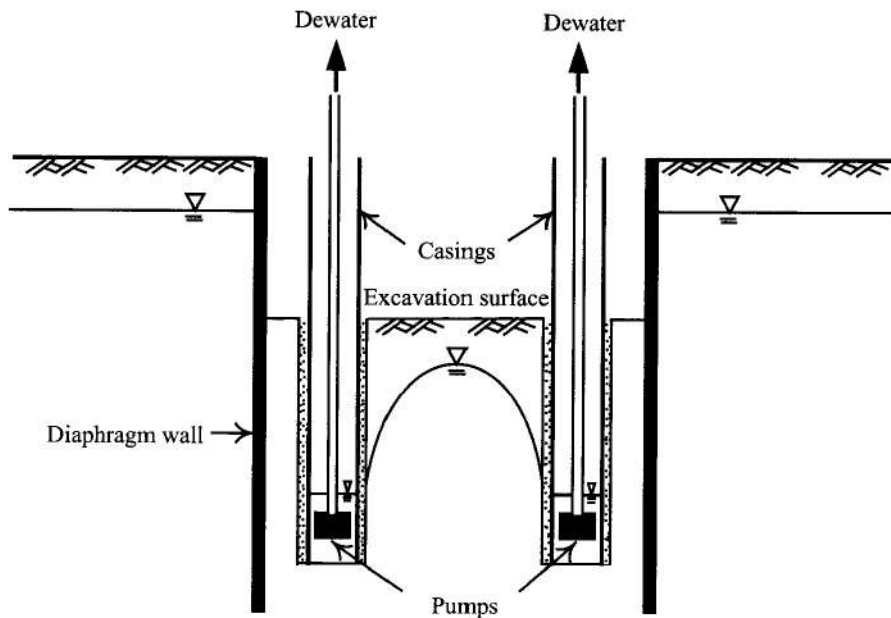

**Deep Well System**

**HORIZONTAL WELL POINTS:** These are used for drainage which is on hill side. The diameter of the wells is 5cm to 8cm. A perforated casing is installed in the well to collect and discharge the water. These are installed at an upward slope for horizontal length of 60m.

### **DEWATERINGBY ELECTRO OSMOSIS**

When an external electro motive force is applied across a solid liquid interface the movable diffuse double layer is displaced tangentially with respect to the fixed layer. This is electro osmosis. As the surface of fine grained soil particles causes negative charge, the positive ions in solution are attracted towards the soil particles and concentrate near the surfaces. Upon application of the electro motive force between two electrodes in a soil medium the positive ions adjacent to the soil particles and the water molecules attached to the ions are attracted to the cathode and are repelled by the anode. The free water in the interior of the void spaces is carried along to the cathode by viscous flow. By making the cathode a well, water can be collected in the well and then pumped out.

Electro osmotic flow is given by

- Electro osmotic consolidation means the consolidation of soft clays by the application of electric current.
- It was studied and applied for the first time by Casagrande.
- It is inherent that fine grained clay particles with large interfacial surface will consolidate and generate significant settlement when loaded.
- The settlement creates problem in the foundation engineering.
- Electro osmosis was originally developed as a means of dewatering fine grained soils for the consolidation and strengthening of soft saturated clayey soils.
- Electro osmotic dewatering essentially involves applying a small electric potential across the sediment layer.
- It is the process where in positively charged ions move from anode to cathode. ie. Water moves from anode to cathode where it can be collected and pumped out of soil
- Electro osmotic flow depends on soil nature, water content, pH and on ionic type concentration in the pore water.
- Due to the applied electric potential the electrolysis of water occurs at the electrodes

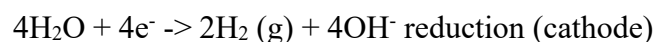
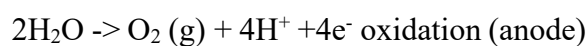

- The clay particles have a –ve charge. These –ve charge produce an electro static surface property known as the double layer which creates a net abundance of cations in pore space.
- Electro osmotic transfer of water through clay is a result of diffuse double layer cations in the clay pores being attracted to a negatively charged electrode or cathode.

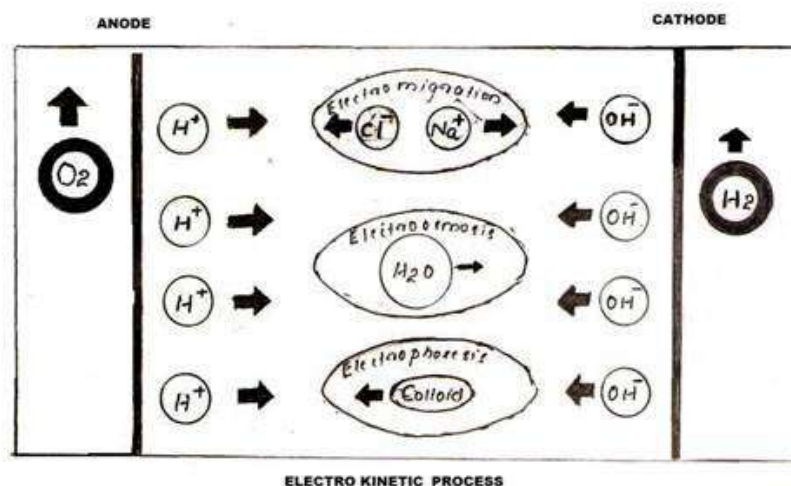

- When electrodes are placed across saturated clay mass and direct current is applied, water in the clay pore space is transported towards cathode by electro osmosis.

- In addition frictional drag is created by the motion of ions as they move through the clay pores helping to transport additional water.
- The flow generated by the electric gradient is called electro osmotic flow.

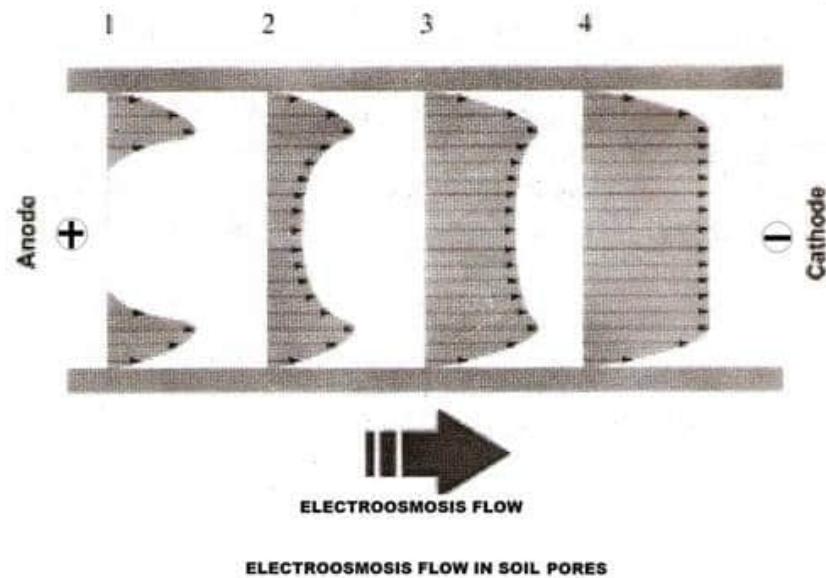

### **Vacuum Dewatering**

In fine sands and silts, with permeabilities of  $10^{-4}$  to  $10^{-6}$  m/sec, water does not flow freely under the influence of gravity, due to capillary tension. To make dewatering and stabilizing of these soils possible, a vacuum may be applied to the sealed off filter section of well. Seepage into the well is then increased due to the influence of atmospheric pressure. Water inflow is generally low and wells may only require intermittent pumping out.

Vacuum action is also present in well point systems which use a combined vacuum and centrifugal pump, the net vacuum applied at the well point is however only equivalent to the vacuum in the header pipe less the lift in the riser pipe. Care has to be taken that all the connections in the pipe system are alright and an effective seal is formed around the riser pipe in its upper section.

To be effective, vacuum wells have to be spaced very closely say 1 to 2.5m apart. The distance between rows of wells should not be more than 15 to 20m.

Submersible pumps in combination with vacuum pumps could provide dewatering to great depth.

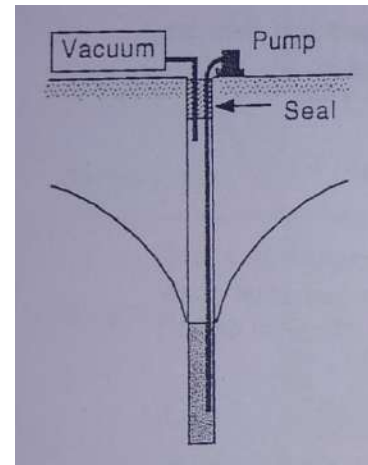
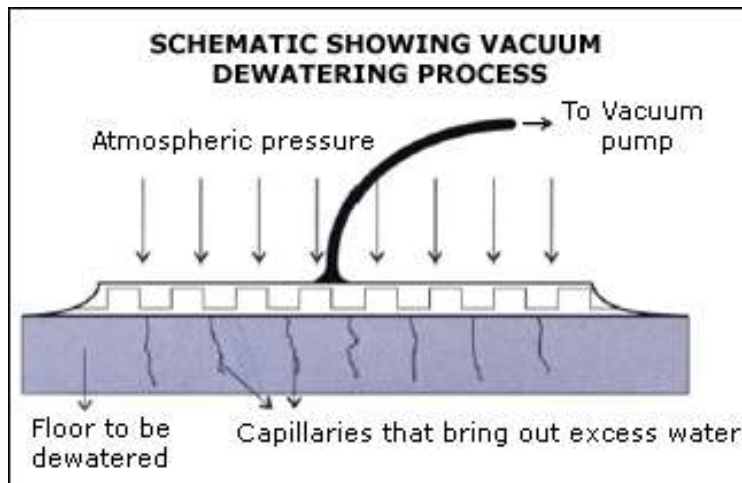

### PRELOADING:

Preloading or precompression increases the bearing capacity and reduces the compressibility of weak ground by forcing loose cohesionless soils to densify the clayey, silty soils to consolidate.

It is achieved by placing a temporary surcharge on the ground prior to the construction of the planned structure.

Preloading with or without vertical drains is only effective in causing substantial settlement if the total applied load significantly exceeds the preconsolidation pressure of the foundation material.

Several advantages compared to the other ground improvement methods are as follows:

1. The cost involved is comparatively less and vary between 10 to 20% without using vertical drains and 20 to 40 % with the use of vertical drains.
2. Very attractive method when fill is used back as fill material in the site preparation for construction.
3. Simple conventional construction equipment needed for earth moving job is sufficient for the preloading works.
4. Cost of monitoring instruments are cheap
5. Effect of preloading can be observed periodically from the field instrumentation.
6. Provide uniform improved properties of ground.

The reason to adopt this technique depends upon the following:

1. There should not be any base failure during preloading or during the operation of final structure.

2. The duration of preloading should be within the time allotted by the construction schedule.
3. There will be no damage to adjoining structure.
4. There will be no undue disturbance to nearby communities.
5. Settlements after construction will be within range of tolerance.
6. Cost is less compared to other methods.

➤ **Principle:**

Preloading increases the pore pressure in soil and then consolidation occurs, where effective stress increases accompanied by surface settlement. The time required for attainment of full consolidation varies directly as the square of the layer thickness and inversely as the permeability.

The ratio of weight used for preloading to the weight of the final structure to be constructed on the improved soil is called **coefficient of surcharge**

➤ **Preloading Methods:**

Heaping or Dumping of fill materials is the most common method of preloading. In some cases, the material is left and the removed material may be reused in the same project. There is a danger of a base failure in this method, but still this method is commonly used as it is less costly for all types of structures and locations. In most of the cases, the embankment loading is used for preloading which takes 3 to 8 months from the embankment placement to the end of removal of loading. The height of preload in most cases is 3 to 8m above the original grade and where the maximum and minimum heights are 1.5m and 18m respectively with usual settlement ranges between 0.3 to 1m.

Another method of preloading is by lowering the water table. In highly permeable soil effect will be more. As the water table is lowered the effect of buoyancy is lost and the soil above the water tables gains unit weight by about  $10\text{kN/m}^3$ . As an approximation, every meter lowering of water table produces settlement that caused by half meter depth of loading by fill. The rate of settlement may be substantially increased by combining the method of lowering the water table and heaping fill.

Another method of preloading is inundating or preponding. Lowering of water table is applicable when the water table is high. But when water table is low, a load can be applied to some soil by opposite action, by inundating or preponding the surface. The effect of preponding is breaking loose bonds between particles, increasing surface tension forces and



weight of water. The combined effect depending on the type of soil cause adequate densification of soil. This technique is also referred to as hydrocompaction.

Another method was proposed by Kjellman (1952) named as Vacuum Preloading method. In this a 150mm layer of sand is placed on the surface of soft clay, the layer is covered with an impervious membrane. An application of a vacuum of 60 to 80 kPa is induced in the sand which acts as an equivalent overload. In its simplest form the method of vacuum consolidation consists of a system of vertical drains and a drainage layer (sand) on top. It is sealed from atmosphere by an impervious membrane. Horizontal drains are installed in the drainage layer and connected to a vacuum pump. To maintain air tightness, the ends of the membrane are placed at the bottom of a peripheral trench filled e. g. with bentonite. Negative pressure is created in the drainage layer by means of the vacuum pump. The applied negative pressure generates negative pore water pressures, resulting in an increase in effective stress in the soil, which in turn is leading to an accelerated consolidation.

#### **DRAINS:**

- **Open Drains:** This method is very old in draining excavations, roads using a ditch or a sump. A sump is said to be a shot ditch which can be constructed even with the unskilled labour.
- **Closed Drains:** When a piping or seepage erosion is creating trouble or where there is desire of permanent drain, the laying of perforated pipe is carried out at a suitable depth in ditches and the ditch is backfilled with suitable filter material. The laying of pipes should be straight. For every 30 to 50m there must be openings to flush out the pipe. At 100m to 150m intervals, the manholes must be provided at changes in direction along straight sections.
- **Horizontal Drains:** If adequate submergence is not available on the situation of field warrant to avoid open-cut work, lowering of ground water can be done with a ranny drainage system. Reinforced concrete shaft or wells are present in this system from which a number of horizontal perforated pipes are fixed. The extension of these pipes may be carried out to a required length in any direction. By using turbine pump, the water collected in the well is pumped out.
- **Foundation Drains:** Used to prevent foundation leaks and building water entry

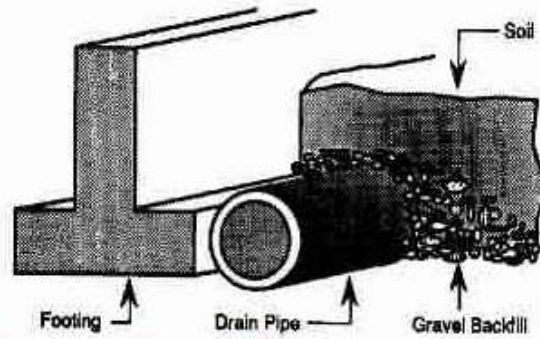

- **Blanket Drains:** A blanket drain is a drainage structure used to accommodate seepage zones on the road cut. The objective is to disperse low-velocity flows over the hill-slope rather than concentrating them in cross-ditches.

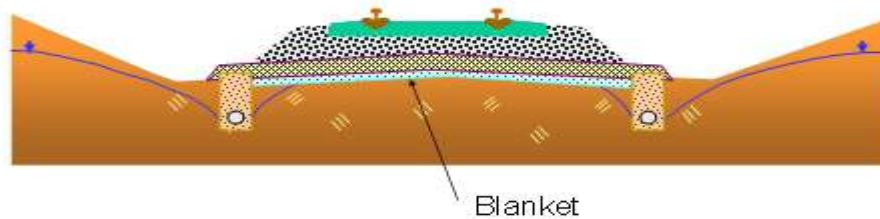

- **Interceptor Drain:** An interceptor drain is a gravel trench that is excavated into a relatively impermeable soil layer and installed to collect and remove groundwater as it flows across the impermeable layer

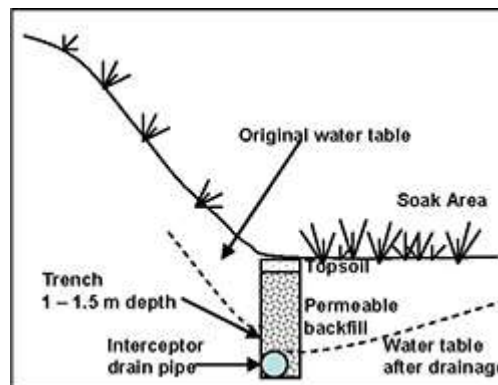

### Vertical Drains:

Vertical drains are installed to accelerate settlement and gain in strength of soft cohesive soil. Without installing vertical drains, bearing failures may occur during placement of the fill and settlement of clay soils may extend over many years. Because highly efficient drain installation methods have been developed, preloading combined with vertical drains has become an economic alternative to the installation of deep foundation or other method of ground improvement.

### Types of Vertical Drains:

Drain type	Installation method	Drain diameter [m]	Typical spacing [m]	Maximum length [m]
Sand drain	Driven or vibratory closed-end mandrel(displacement type)	0.15 – 0.6	1 - 5	≤ 30
Sand drain	Hollow stem continuous flight auger (low displacement)	0.3 – 0.5	2 - 5	≤ 35
Sand drain	Jetted (non-displacement)	0.2 – 0.3	2 - 5	≤ 30
Prefabricated sand drains (sand-wicks)	Driven or vibratory closed-end mandrel; flight auger; rotary wash boring (displacement or non-displacement)	0.06 – 0.15	1.2 - 4	≤ 30
Prefabricated band-shaped drains	Driven or vibratory closed-end mandrel(displacement or low displacement)	0.05 – 0.1	1.2 – 3.5	≤ 60

#### ➤ Sand drains:

Sand drains simply consisted of boreholes filled with sand. The holes may have been formed by boring or drilling or augering and would have diameters of 200 to 450mm with spacing 1.5 to 6m apart.

A large diameter sand, or gravel drain, in a fine grained soil not only enables consolidation of surrounding material but also provide vertical compressive reinforcement that could transfer surface loads to strong bearing stratum at depths. The higher the reinforcing effect, lower will be the consolidation stresses in the foundation soil. So large diameter gravel drains, therefore would not serve the purpose of preloading.

#### ➤ Prefabricated or Geosynthetic Drains:

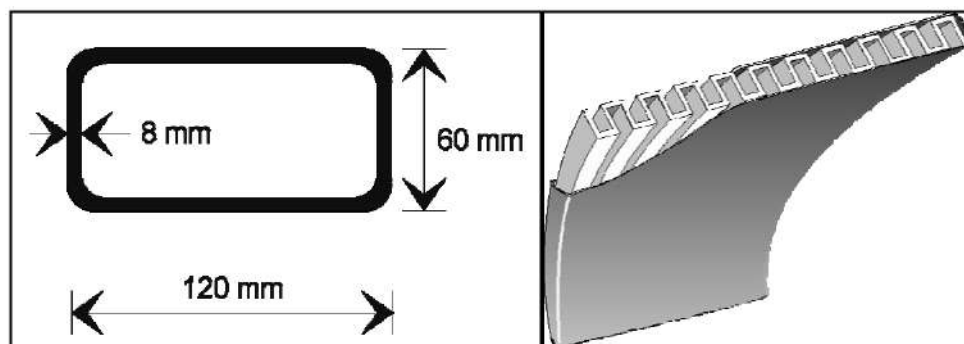

Most synthetic drains are of a strip shape, although circular plastic drainage pipes wrapped in a geotextile could also serve as vertical drain.

The first strip drain was developed by Swedish Geotechnical Institute by Kjellman. It was made of cardboard with internal ducts. This type was later superseded by thin fluted PVC drains. Today, there are many different kinds of drains available in market.

Advantages of Geosynthetic Drains over sand drains:

- Easy, Simple installation is possible.
- Made of uniform material, easily stored and transported
- Equipment needed is lighter than the rigs required for sand drains
- Tensile strength of the strips helps to preserve continuity
- Low costs

### **DESIGN OF VERTICAL DRAINS:**

Many theories have been proposed over the years based upon various assumptions about the homogeneity of the soil, the variations with time of the permeability and coefficient of consolidation, the appropriate hydraulic flow law, drain effects loading rate and creep effects. A review on vertical drains was made by Richart (1959) and Johnson (1970). The basic theory of vertical drains which has been in use till today is Reudulic (1935) and Barron (1948). In this analysis of theories two conditions prevail;

- i. Free-Strain Conditions: Applications of a flexible surcharge load will cause an uneven settlement at the surface and this condition is referred to as free strain condition.
- ii. Equal-Strain Condition: Applications of a rigid surcharge load will cause an equal settlement at the surface and this condition is referred to an equal strain condition.

The theoretical design of vertical drain is based upon the independent behaviour of each drain in the center of a cylindrical soil mass. Considering a element of soil with vertical and radial flow and developing the governing equations similar to one dimensional theory, we have

Where  $c_v$  is the coefficient of vertical consolidation and  $c_h$  is the coefficient of radial or horizontal consolidation, where  $k_v$  and  $k_h$  are referred to as vertical and horizontal permeabilities.

Equation  $A$  is the governing differential equation for three dimensional consolidation and may be considered to consist of two parts:

One dimensional flow:

Radial Flow:

A solution of Equation A has been considered by Carilo (1942) as a combination of solutions of equation B and Equation C and accordingly we have

Where  $U$  = degree of consolidation for three dimensional flow

$U_z$  = degree of consolidation for one dimensional flow

$U_r$  = degree of consolidation for radial flow

Time factor for one dimensional flow

Time factor for radial flow

Where  $r_e$  is radius of influence

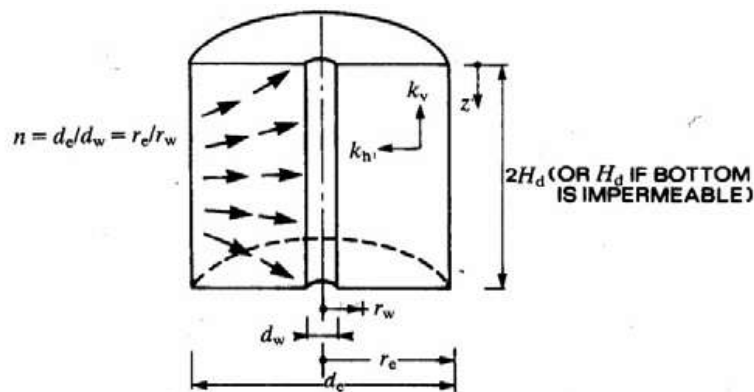

Solutions for the equation B was given by Rendulic (1935) for free Strain Condition and by Barron (1948) for equal strain condition. It has been reported by Richart (1959) for values of  $n$  greater than five, both the solutions give almost the same value.

**Efficiency of vertical drains:** The efficiency of system of vertical drains is assessed with reference to the primary consolidation attained with and without installation of vertical drains has been expressed by Bjerrum(1972) as

Where  $U_p$  and  $U_s$  are primary and secondary compression.

## UNIT-III

### PHYSICAL AND CHEMICAL STABILISATION

**Objective:** To know about the different stabilisation techniques available to strengthen the soil for constructions and other works.

**Syllabus:** Physical and Chemical Stabilization

Cement Stabilization, Lime Stabilization, Calcium Chloride Stabilization, Fly ash Stabilization and Bitumen Stabilization.

**Outcomes:**

Student will be able to

- Know different methods of stabilisations
- Idealize the working procedure involved in each method
- Know about different functions and suitability of each stabilising process

### LEARNING MATERIAL

#### CEMENT STABILISATION:

Cement stabilization is done by mixing pulverised soil and Portland cement with water and compacting the mix to attain a strong material. The material obtained thus obtained is called soil-cement.

**Types of soil cement:**

1. **Normal soil cement:** It consists of 5 to 14% cement by volume. The quantity of cement mixed with soil is sufficient to produce a hard and durable construction material. The amount of water used should be just sufficient to satisfy hydration requirements of the cement to make workable.
2. **Plastic soil cement:** This type of soil cement also contains cement 5 to 14% by volume, but it has more quantity of water to have wet consistency similar to that of plastering mortar at the time of placement. The plastic soil cement can be placed on steep or irregular slopes where it is difficult to use normal road making equipment. The plastic soil cement can be used for protection of steep slopes against erosive action of water.
3. **Cement Modified Soil:** It is a type of soil cement that contains less than 5% of cement by volume. As quantity of cement is small, it is not able to bind all the soil particles but it

reduces the swelling and shrinkage properties of the soil.

The important factors affecting the soil-cement are nature of soil content, conditions of mixing, compaction, curing and admixtures used.

**Factors affecting cement stabilization:**

- a) **Type of soil:** Granular soils with sufficient fines are ideally suited for cement stabilization. Such soils can be easily pulverized and mixed. They require least amount of cement.

Granular soils with deficient fines can be stabilized but require more cement. Whereas, silty and clayey soils can produce soil cement but with high clay content in soil is difficult to pulverize. Moreover, the quantity of cement required is more for high clay content is more.

- b) **Quantity of Cement:** A well graded soil requires about 5% cement, whereas poorly graded; uniform sand may require about 9% cement. Non plastic silts require about 10% cement, whereas plastic clays may need about 13% cement.

The actual quantity of cement required for a particular soil is ascertained by laboratory tests. To determine quantity of cement durability tests are conducted which consists of 12 cycles of wetting and drying with a volume change of 2% that is permitted.

Sometimes quantity of cement is determined according to minimum unconfined compressive strength which is generally considered as 1500kN/m<sup>2</sup> for clayey soils and 5500kN/m<sup>2</sup> for sandy soils. High strength is obtained by decreasing the water cement ratio. As a rough guide, 6% of cement for sandy soils and 15% for clayey soils is considered.

- c) **Quantity of water:** The quantity of water used must be sufficient for hydration of cement and silt clay cement. Water used should be clean and free from harmful salts, alkalies, acids or organic matter.
- d) **Mixing, Compaction and Curing:** The mixture of soil, cement and water should be thoroughly mixed, as the success of cement stabilisation depends mainly on thorough mixing. If it is not mixed properly, it may results in non-homogeneous weak product.

Soil cement should be properly compacted. For good results, fine grained soils

compacted at wet of optimum and coarse grained soils compacted at dry of optimum.

- e) **Admixture:** To increase the effectiveness of cement as stabilizer, admixtures are sometimes added to soil cement as a replacement of cement in the mix which reduces cement content. Lime and calcium chloride used for harmful organic matter to make them more responsive to cement. Likewise Flyash for dune sand, and many more like sodium carbonates and sodium sulphates.

### **Construction Methods:**

**MIX IN PLACE METHODS:** In this method of construction, mixing of soil cement is done at the place where it would be finally placed.

The subgrade is cleared of all undesirable material and levelled and the material on subgrade is pulverized till at 80% of soil passes 4.75mm IS sieve which can be done manually or mechanically with help of machine. The pulverized material is spread uniformly and required quantity of water is sprinkled over the surface and wet mixing is done till the mixture is uniform. Compaction should be done by suitable machines. The compacted soil-cement is moist cured for at least 7 days by providing a bituminous primary coat.

### **PLANT MIX METHOD:**

**Stationary plant:** In this method, the excavated soil is transported to a stationary plant located at a suitable place. Then required quantity of cement is added to the soil in the plant with proper mixing is done after applying water into the plant. The mixed material is then discharged into dumpers, trucks and transported back to the area subgrade to be made ready. Uniform mix can be obtained in this method.

Quite expensive method compared to mix in place method.

**Travelling Plant:** A travelling plant can move along the road under construction. The soil after placement of cement is lifted up by an elevator and discharged into the hopper of the mixer of the travelling plant. Water is added and proper mixing is done. The mix is then discharged on the subgrade and spread by a grader. It is then properly compacted.



## LIME STABILISATION

### Soil lime reactions:

1. **Hydration:** Quick lime will absorb moisture from the soil and reacts instantly. This reaction is known as slaking of lime, which will increase its volume by 2.25 times of its volume, thus exerting large lateral thrust on the sides of bore holes. The process of removal of water from soft soil completely with the lateral pressure causes consolidation of the clay bed.

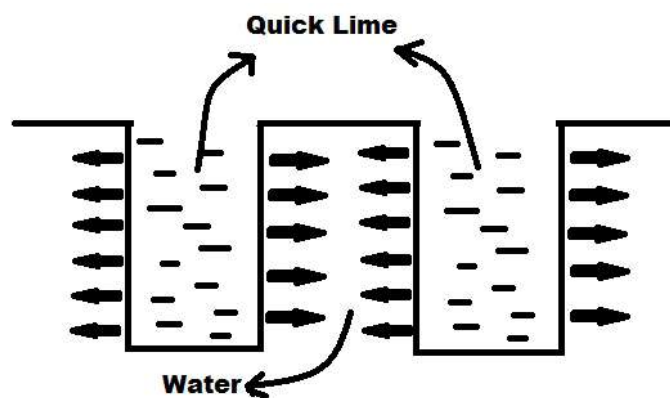

2. **Flocculation:** Replacement of monovalent cations like sodium, lithium, etc by divalent cations from lime decreases the thickness of double layer water around the clay mineral particles, thus increasing the attracting forces between the soil particles. This helps soil particles to flocculate together, thus reducing their specific surface area which brings down the activity of clay.
3. **Cementation:** When lime is added to clay, its pH value increases beyond 12 where the silica and alumina from the clay particles will be liberated due to high alkalinity. Calcium from lime reacts with the silica and alumina in the presence of water, thus forming hydrated calcium silicate and calcium alumino silicate hydrates which are cementing compounds. However requires large time period for reactions.
4. **Carbonation:** It involves absorption of  $\text{CO}_2$  from the atmosphere and the formation of  $\text{CaCO}_3$  and  $\text{MgCO}_3$ . The contribution of carbonation is generally negligible.

### Engineering properties of Lime stabilisation:

1. **Plasticity:** Upon addition of lime, the plasticity of clayey soils will be thoroughly modified by the cation exchange. The soil becomes workable and friable thus making compaction possible.

2. **Dry density:** The OMC of lime stabilized soil increases with the corresponding reduction in the dry density. However, the compaction curve becomes flatter making soil irresponsive to moisture changes.

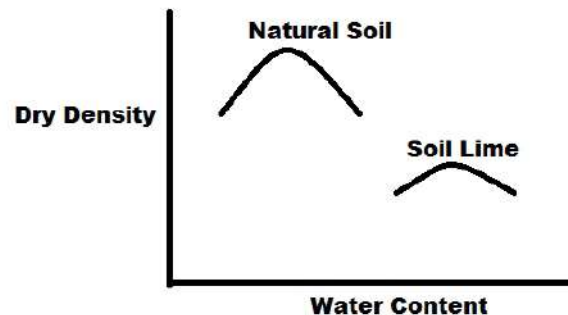

3. **Strength:** The addition of lime to soil increases its UCC and CBR upto an optimum lime content and thereafter decreases due to the presence of free lime.
4. **Permeability:** The permeability of lime stabilized soils increases due to the flocculated structure with the larger size of pores. The increased value of  $k$  helps to relieve the developed pore water pressures quickly.
5. **Swelling and Shrinkage:** Treatment of expansive clays by lime helps to reduce the degree of volume change.

#### **Mechanism/Applications of soil lime:**

It is used to modify the clayey soils or used as binder. Clayey soils of high plasticity are treated with lime and the plasticity is decreased, the soil becomes friable and easy to pulverize, have less affinity with water. Lime imparts binding action in granular soils.

In fine grained soils, due to puzzolonic action, with the addition of cement, the strength will be increasing.

When clay is treated with lime, the various possible reactions are:

1. Base Exchange
2. Coagulation or flocculation
3. Reduction in the thickness of water film around the clay particles.
4. Cementing action
5. Carbonation

### Uses of Soil Lime:

- Quite suitable as sub base courses for pavements
- Used as a base course for pavements with low traffic.
- Soil lime cannot be used as surface course even for light traffic in view of its very poor resistance to abrasion and impact.
- Soil lime is quite suitable in warm regions but not suitable for freezing temperatures.

### Factors affecting the properties of soil lime:

1. **Soil type:** The soil properties affect the base exchange characteristics and pozzolonic action. The proportion of increase in strength in a soil lime mix depends on the pozzolone in the soil.
2. **Lime content:** An increase in lime content causes a slight change in liquid limit and also in plastic limit. Reduction in the plasticity index, increase in the compressive strength is also observed with the curing time.
3. **Compaction:** It is done at OMC and MDD. The maximum dry density can be obtained at the optimum of lime content.
4. **Curing:** The strength of soil lime increases with the curing period of several years. The rate of increase in strength is rapid during the initial period of curing which also depends on temperature.

At low temperature the rate of strength gain decreases considerably and below freezing point, practically there is no gain in strength. The humidity of the surrounding during curing also affects the strength.

5. **Additives:** Addition of lime alone with soil often does not increase the strength of the mix as desired. Portland cement, Pozzolonic materials like fly ash, steel slag, and surkhi are used at the desired percentages. Chemical additives like sodium metasilicate, sodium hydroxide and sodium sulphate are useful to stabilize lime soil for desirable strength.

### Construction of soil lime base course:

**Materials:** The soil to be stabilized is scarified. Even high plastic soils can also be suitably modified by lime for OMC and MDD. Fresh stock of hydrated lime or quick lime can be used. It is desirable that the lime available is made of fine powder.

**Plants and Equipment:** The equipment needed is for scarifying, mixing and compaction

### ***Construction Steps:***

- Preparation of subgrade
- Pulverization of soil to be stabilized
- Addition of part of lime as dry powder or as slurry with water and mixing
- Allowing the mixture to age for about a day, thus remixing becomes easy.
- Adding the rest of the lime and water, if necessary and remixing
- Spreading to the desired rate and compaction
- The soil lime is protected from drying out and it allows moist curing.
- Field control tests include checking moisture content at the time of compaction and checking dry density soon after the compaction.

### **BITUMINOUS STABILISATION**

Bitumen a petroleum product obtained by the destructive distillation of crude petroleum. Tar is obtained by the destructive distillation of coal. Asphalt consists of inert mineral particles cemented by bitumen. The use of all three minerals in soil stabilisation is collectively called as bituminous stabilization. It can be adopted for clay and sands provided they can be mixed with bitumen. In clays it helps to repel water making it insensitive to moisture changes. In cohesionless soils, bitumen binds the particles.

### **Types of Soil-Bitumen:**

1. ***Soil Bitumen:*** It is a water proofed cohesive soil system. It consists of 4-7% bitumen.
2. ***Sand Bitumen:*** Sand Particles are cemented together with bitumen. It consists of 4-10% bitumen.
3. ***Water Proofed Granular soils:*** Granular soils with low plastic fines can be stabilized using a small percentage of bitumen (1-2%).
4. ***Oiled Earth:*** A Bituminous emulsion or cut back is sprayed on the soil surface to make it water proof. It requires 4-5 litres of bitumen per m<sup>3</sup>. Normally bitumen is applied in the form of emulsion.

### **Engineering Properties of Soil Bitumen:**

1. **Optimum Moisture Content:** Stabilisation of soil with bitumen results in the reduced dry density and also reduced OMC. The reduction in OMC is attributed to the additional lubrication effect of bitumen.
2. **Strength:** The UCC of soil bitumen increases upto an optimum content and thereafter decreases.
3. The performance of the soil bitumen in practise depends on the % fines in the soil. Higher % fines increases the dry density but softens the material under wet condition.

### **Principle of Soil Bitumen:**

The principle involved in soil bitumen is its water proofing and binding characteristics. By water proofing, the inherent strength and other properties of the soil could be retained. For soils, both binding and water proofing action are provided. In granular soils, the coarser grains may be individually coated and struck together by a thin film of bituminous material. In fine grained soils, bituminous material plugs up the voids between the small soil clogs and thus water proofing the compacted soil bitumen. Most commonly used materials are cut back or emulsions.

### **Factors affecting the properties of soil bitumen:**

1. **Soil type:** Depends on the particle size, shape and gradation. Small portion of fines in the soil is preferable. High clay content is not desirable.
2. **Proportion of bituminous material:**
  - i. **Type of bituminous material:** Cut back of different grades give different stability values of soil. Higher grade and type of cut back is preferred. Emulsions generally give slightly inferior results than cut-back.
  - ii. **Amount of Bitumen:** Increasing percentage of bitumen causes a decrease in the maximum dry density of soil bitumen. Stability increases upto an optimum of bituminous content and then decreases with the increase in the percentage of bitumen content.
3. **Mixing:** Low mixing period and uniform mixing is required. Mix the soil first and then add the cut back.
4. **Compaction:** Better the compaction, higher will be the stability and resistance to absorb

water. Also depends on the compaction moisture content and the temperature.

5. **Curing:** Air curing or curing with the open atmosphere. The water and the volatiles are evaporated and the bitumen to be effective to impart the binding and water proofing action. Depends on the curing temperature, humidity and soil type.
6. **Additives:** Anti-stripping and reactive chemical additives have been tried to improve the properties of the mix with varying degree of success. Portland cement is also sometimes used along with soil bitumen to increase the stability of the mix.

### **Construction of Bituminous Stabilized layer:**

1. **Materials:** Soil is pulverized and stacked. Properties of soil to be preferred are as follows:

Passing through 4.75mm sieve	<50%
Passing through 0.425mm Sieve	35 – 100%
Passing through 0.075mm Sieve	10 – 50%
Liquid Limit	< 40%
Plastic Limit	< 18%

2. **Plants and Equipment:** Plants and equipment are needed for scarifying, pulverising, mixing and compaction.
3. **Construction Steps:**
  - The soil to be stabilized is pulverised.
  - Water is added to the soil and then mixed.
  - Cut back or emulsion is added.
  - The mix is spread, graded and compacted.
  - The compacted layer is allowed to cure, where the moisture and volatiles of the solvent evaporate from the soil mass.

Field control tests include the following:

- i. Checking of pulverization of wet mixed soil.
- ii. Checking of moisture content and bitumen before compaction.
- iii. Checking of dry density of compaction.

## **CALCIUM CHLORIDE STABILIZATION:**

Calcium Chloride has been used in highway construction & maintenance. It is generally a by-product in making sodium carbonate or from other chemical processes. In Australia, it is available as PACWET, obtained by reacting lime or limestone with hydrochloric acid (HCl) i.e., by-product in manufacture of fluorocarbons.

### **Physical Properties:**

It is an inorganic salt with a number of physical properties which makes advantageous to Geotechnical Engineering.

- **Hygroscopicity:** Calcium chloride is hygroscopic, which attracts and absorbs moisture content from atmosphere i.e., a function of relative humidity and temperature.
- **Deliquescence:** A deliquescent substance is one that liquefies in moisture of its own absorption. (Becoming liquid or having a tendency to become liquid).
- **Solubility:** Calcium chloride is highly soluble (59.5g/ 100ml of water). According to Slessor(1943), solubility of substance in water is a major factor that determine the extent of which vapour pressure, density, freezing point of water can be altered by addition.
  - **Vapour Pressure:** Tendency of a substance to pass from liquid/solid to gaseous state. Vapour pressure of a calcium chloride solution is always lower than that of water.
  - **Surface tension:** Calcium chloride has higher surface tension than water.
  - **Freezing point:** Calcium chloride has lower freezing point than water completing freezing of calcium chloride occurs at  $-51^{\circ}\text{C}$ .

### **Effects of soil Properties:**

- **Soil Structure:** Calcium chloride has several physico-chemical effects on fine grained component of soil. If sodium ions ( $\text{Na}^+$ ) are present around negatively charged clay surface, they will be replaced with calcium ( $\text{Ca}^{++}$ ), which reduces the thickness of double layer, upon lowers plasticity and increases strength by strengthening molecular bonds between particles.
- **Compaction properties:** In Gravelly clay soils, if calcium chloride is added it attributes to increased surface tension of moisture and increased density of pore water.

However, calcium chloride reduces evaporative water losses from soil that facilitates moisture content during construction and controls of dust generation on unpaved roads.

### **Uses:**

- The most appreciated use of calcium chloride is as a dust palliative on highly trafficked unpaved roads where it causes problems of poor visibility, increased vehicle wear and adversely affects the environment. So keeping the road surface moist, less dust will be created where addition of calcium chloride helps keeping the moisture content for a longer period.
- As a secondary additive also brings benefits in cement or lime stabilization by increasing early strength values with a minimum of 0.5 to 1.5% of calcium chloride addition.
- Many uses of Calcium chloride can be found in electro-kinetic stabilization & grouting.

**Construction Steps:** The same process as if in lime stabilization can be done.

### **FLY ASH STABILIZATION:**

Fly ash is a solid waste product created by the combustion of coal. It is carried out of the boiler by the flue gases and extracted by electrostatic precipitators or cyclone separators and filter bags. Its appearance is generally that of a light to dark gray powder of predominantly silt size.

Making more productive use of fly ash would have considerable environmental benefits with reduced land, air and water pollution. Increased use as a partial cement or lime replacement would also represent a savings in energy (Fly ash has been called a high energy waste material).

Besides using fly ash alone as a structural fill material, scope exists for employing techniques of ground modification to find more medium to high volume applications in the following ways:

- Add cement or lime to stabilize the fly ash.
- Stabilize soils with cement lime fly ash mixes.
- Use fly ash in the containment of toxic wastes.

### **Properties of fly ash:**

- Chemical composition and reactivity: A microscopic view of fly ash reveals mainly glassy spheres with some crystalline and carbonaceous matter. The principal chemical constituents are silica ( $\text{SiO}_2$ ), Alumina ( $\text{Al}_2\text{O}_3$ ), ferric oxide ( $\text{Fe}_2\text{O}_3$ ) and calcium oxide ( $\text{CaO}$ ). Other components are magnesium Oxide ( $\text{MgO}$ ), Titanium Oxide ( $\text{TiO}_2$ ), Alkalies ( $\text{Na}_2\text{O}$  and



K<sub>2</sub>O), Sulphur trioxide (SO<sub>3</sub>), Phosphorous Oxide (P<sub>2</sub>O<sub>5</sub>).

- Water added to fly ash usually creates an alkaline solution, with a pH ranging from 6 to 11.
- Fly ash is a heterogeneous material.
- Factors affecting the physical, chemical, and engineering properties of fly ash include:
  - Coal type and purity
  - Degree of pulverization
  - Boiler type and operation
  - Collection and stockpiling methods
- In this process, Cementitious calcium silicate and calcium aluminosilicate hydrates are formed when glassy components of the fly ash react with water and lime.
- Critical to the pozzolanicity of the fly ash are conditions such as
  - Amount of silica and alumina in the fly ash
  - Presence of moisture and lime
  - Fineness of the fly ash
  - Low carbon content
- The degree of self hardening of ash is also highly dependent on the ash's density, temperature and age.

### **Engineering Properties:**

- The specific gravity of the ash particle ranges from 1.9 to 2.5, which is below that of soil solids.
- The average grain size D<sub>50</sub> of fly ash is likely to be in the range of 0.02 to 0.06mm. Fly ash is non plastic and in dry state it is cohesionless. The lack of cohesion makes non hardening fly ash highly erodible. In moist state, surface tension of the pore water gives fly ash an apparent cohesion and when pozzolanic reaction occurs, unconfined compression strength is increased with age.
- Compacted ash may have a dry density between 1.2 and 1.9 t/m<sup>3</sup> with a corresponding optimum moisture content from 30 to 15% respectively.
- Compression index of fly ash can range from 0.05 to 0.37 for initial loading. In recompression, these values are much lower of 0.006 to 0.04.

### **Effect of other material with fly ash for stabilization:**

- For cohesionless soils or soils with low plasticity, cement will be more effective than lime,

either alone or combined with fly ash.

- For more plastic soils, either cement or lime may be added with fly ash.

## UNIT-4– REINFORCED EARTH TECHNOLOGY

**Objective:** To know about the reinforcement in soil.

**Syllabus:** Reinforced Earth Technology

Concept of soil reinforcement, Reinforcing materials, Backfill criteria, Design of reinforcement for internal stability, Applications of Reinforced earth structures, Soil nailing and applications

**Outcomes:**

Student will be able to

- Know the technique of reinforcing the soil
- Work with design and stability conditions with respect to the safety factors.

### LEARNING MATERIAL

The concept of combining two materials of different strengths characteristics to form a composite material of greater strength is quite familiar in civil engineering practices and is in use for ages. The reinforced concrete constructions are examples for such composite materials. It combines the high tensile strength of steel with the high compressive, but relatively low tensile strength of concrete. Likewise, soils which have little if any tensile strength can also be strengthened by the inclusion of materials with high tensile strength. This mobilisation of tensile strength is obtained by surface interaction between the soil and the reinforcement through friction and adhesion. The reinforced soil is obtained by placing extensible or inextensible materials such as metallic strips or polymeric reinforcement within the soil to obtain the requisite properties.

Soil reinforcement through metallic strips, grids or meshes and polymeric strips sheets is now a well developed and widely accepted technique of earth improvement. Anchoring and soil nailing is also adopted to improve the soil properties.

The use of reinforced earth technique is primarily due to its versatility, cost effectiveness and ease of construction. The reinforced earth technique is particularly useful in urban locations where availability of land is minimum and construction is required to take place with minimum disturbance traffic.

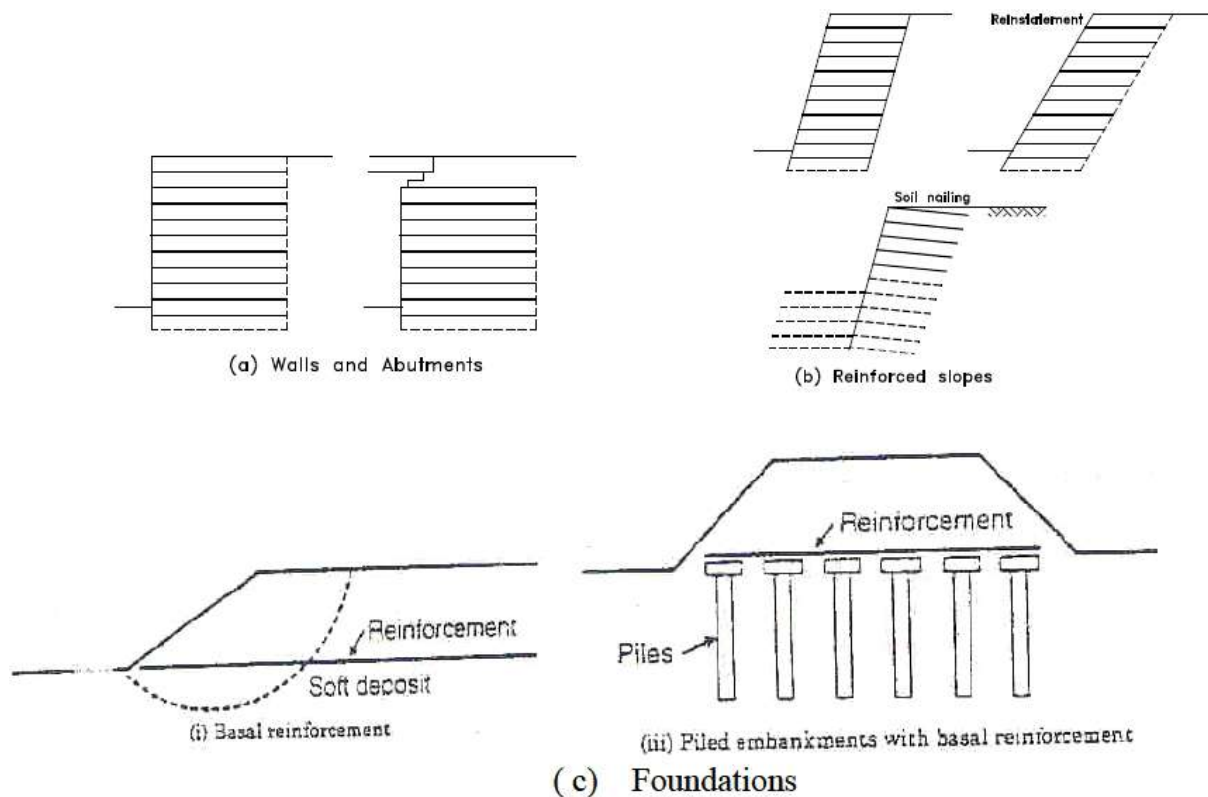

### Description of reinforcing element:

A variety of materials can be used as reinforcing materials. Those that have been used successfully include steel, concrete, glass fibre, wood, rubber, aluminium and thermoplastics. Reinforcement may take the form of strips, grids, anchors & sheet material, chains planks, rope, vegetation and combinations of these or other material forms.

### Types of reinforcing materials:

#### Strips:

These are flexible linear element normally having their breadth, 'b' greater than their thickness, 't'. Dimensions vary with application and structure, but are usually within the range  $t = 3-5 \text{ mm}$ ,  $b = 5-100 \text{ mm}$ . The most common strips are metals. The form of stainless, galvanized or coated steel strips being either plain or having several protrusions such as ribs or gloves to increase the friction between the reinforcement and the fill. Strips can also be formed from aluminium, copper, polymers and glass fibre reinforced plastic (GRP). Reed and bamboo reinforcements are normally categorized as strips, as are chains.

### Planks:

Similar to strips except that their form of construction makes them stiff. Planks can be formed from timber, reinforced concrete or prestressed concrete. The dimensions of concrete planks vary; however, reinforcements with a thickness, 't' = 100 mm and breadth, b= 200–300 mm have been used. They have to be handled with care as they can be susceptible to cracking.

### Grids and Geogrids:

Reinforcing elements formed from transverse and longitudinal members, in which the transverse members run parallel to the face or free edge of the structure and behave as abutments or anchors. The main purpose is to retain the transverse members in position. Since the transverse members act as an abutment or anchor they need to be stiff relative to their length. The longitudinal members may be flexible having a high modulus of elasticity not susceptible to creep. The pitch of the longitudinal members,  $p_L$  is determined by their load-carrying capacity and the stiffness of the transverse element. The pitch of the transverse elements,  $p_T$  depends upon the internal stability of the structure under consideration. A surplus of longitudinal and transverse elements is of no consequence provided the soil or fill can interlock with the grid.

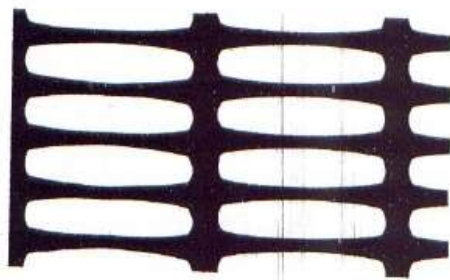

(a) Mono Oriented geogrid

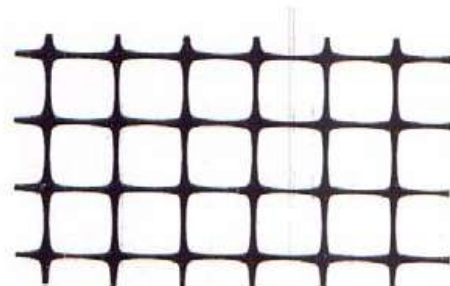

(b) Bi-Oriented geogrid

Grids can be formed from steel in the form of plain or galvanized weld mesh, or from expanded metal. Grids formed from polymers are known as “Geogrids” and are normally in the form of an expanded proprietary plastic product.

Sheet reinforcement:

May be formed from metal such as galvanized steel sheet, fabric (textile) or expanded metal not meeting the criteria for a grid

Nailing:

Earth may be protected by geosynthetics with earth nailing.

Anchors:

Flexible linear elements having one or more pronounced protrusions or distortions which act as abutments or anchors in the fill or soil. They may be formed from steel, rope, plastic (textile) or combinations of materials such as webbing and tyres, steel and tyres, or steel and concrete as shown in Fig.

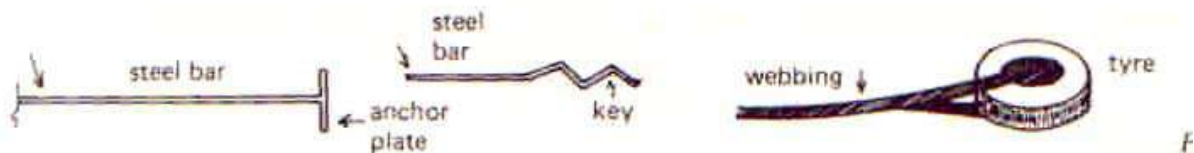

Composite reinforcement:

Reinforcement can be in the form of combinations of materials and material forms such as sheets and strips, grid and strips and anchors, depending on the requirements.

In reinforcement with polymers, polymeric joints are required. Polymeric reinforcement joints are subdivided into prefabricated joints and joints made during execution of the works . A number of different jointing systems are in use. Joints in geotextiles should normally be sewn where load transference is needed.

### **Description of Soil Backfill**

The fill material for reinforced earth structures shall be preferably cohesionless and it should have an angle of on interface friction between the compacted fill and the reinforcing element of not less than 30, measured in accordance with IS 13326 Part (I). The soil should be predominantly coarse grained; not more than 10 percent of the particles shall pass 75 micron sieve. The soil should have properties such that the salts in the soil should not react chemically or electrically with the reinforcing element in

an adverse manner.

A wide variety of fill types can be used with the grids including crushed rock, gravel, industrial slag, pulverised fuel ash and clay, but fill particles greater than 125 mm should be avoided.

**The design of a Reinforced Earth wall requires the verification of:**

➤ Internal stability, local equilibrium justification for each reinforcing strip layer,

Checking:

- The tensile strength,
  - The soil/strip adherence
- External stability, performed by considering the RE wall as a block:
- Sliding on the base,
  - Bearing capacity of the subsoil
- Compound (or combined) stability,
- Global stability

In the reinforced earth wall two type of stability checked:

**External stability:** It consider the reinforced structure as whole and check the stability for sliding, overturning, bearing/tilt and slip by considering the effects of dead loads, other loads (live load, dynamic load etc.) and forces acting on the structure.

**Internal stability:**

It covers internal mechanism (tension and pull out failure) such as shear within the structure, arrangement and behavior of the reinforcement and backfill. It checks the stability for each reinforcement layers and stability of wedges within the reinforced fill

Seismic Stability:

High performance during the 1995 Kobe Earthquake of a GRS RW of this type that had been constructed at Tanata validated its high seismic stability

**DESIGN OF INTERNAL STABILITY**

Stability within a reinforced structure is achieved by the reinforcing elements carrying tensile forces and then transferring to the soil by friction, friction and adhesion, or friction and bearing. In addition forces can be transferred the soil through fill trapped by the elements of the grid. The fill is than able to support the associated shear and compressive forces. In the case of anchored earth such as soil nailing, stability within a structure is achieved by the

anchor elements carrying tensile forces and transferring these by friction along the anchor shaft or anchor loop and bearing of the anchor to the surrounding fill.

The internal stability is concerned with the integrity of the reinforced volume as a whole and also whether the structure has the potential to fail by the rupture or loss of bond of reinforcements. The analysis considers the local stability of individual layer of reinforcing elements and stability of several wedges originating at different height at angle  $45 - \phi/2$ , where the tensile force required to be resisted is maximum within the reinforced fill. The arrangement and layout of reinforcing elements should be chosen to provide stability and to suit the size, shape and detail of facing.

The simplest layout is a uniform distribution of identical reinforcing element throughout the length and height of the structure. A more economical layout may be achieved using reinforcement of different properties or by dividing the structure in to different zones with different spacing of height.

**The allowable tensile strength for one strip ( $T_r$ ) is given by:**

$$T_r = \rho_{end} \cdot \rho_{flu} \cdot \rho_{deg} \cdot \frac{T_{lim}}{\gamma_{M;t}}$$

**Where:**

$T_{lim}$ : initial ultimate tensile strength (*respectively* yield strength) of the strip,

$\rho_{end}$ : reduction factor due to installation damage (= 1 for steel strips),

$\rho_{flu}$ : reduction factor due to creep (= 1 for steel strips),

$\rho_{deg}$ : reduction factor due to environmental chemical and biological degradation. For steel strips, this factor represents the loss of strength due to the loss of thickness with time.

$\gamma_{M;t} = 1.25$  (*resp.* 1.00): partial safety coefficient on ultimate (*resp.* yield) tensile limit of the strip material.

**Partial safety factor:**

**1.00** on yield stress (*steel reinforcements*)

**1.25** on tensile failure



### **Pull-out capacity (soil/strip adherence)**

The strips are anchored in the resistant zone

The pull-out capacity ( $r_f$ ) is a function of:

Adherence length  $L_a$

Total horizontal surface of the strips ( $n \cdot b \cdot 2$ ),  $n$  strips of  $b$  width on 2 faces on 1m

Average vertical stress ( $\sigma_v$ ) along  $L_a$

Friction coefficient  $\mu^*$

**Partial safety factor: 1.35**

The advantages of reinforced earth can be summed up as:

- 1) Saving in material and labour, and vast overall economy,
- 2) Large number of potential uses,
- 3) Speed of execution – no special skill is needed for erection,
- 4) High resilience to withstand dynamic effects, such as from blasts, and high seismic stability,
- 5) Advantages of using precast elements, the in-situ work involved being only laying and jointing them,
- 6) Ease of adaptation to curved alignments,
- 7) Ability to withstand considerable settlements without damage, thanks to its flexibility,
- 8) High aesthetics in landscaping.

### **SOIL NAILING**

Soil nailing is the method of reinforcing the soil with steel bars or other material. It has been alternative technique to other conventional supporting system as it offers flexibility, rapid construction & competitive cost. The purpose is to increase the Tensile & Shear Strength of the soil & Restrain its displacements. Soil nailing is a construction technique used to reinforced soil to make it more stable. In this technique, soil is reinforced with slender elements such as reinforcing bars which are called as nails. These reinforcing bars are installed into pre-drilled holes and then grouted.

## **APPLICATIONS:**

Soil Nail Walls for Temporary and Permanent Cut Slopes.

Retaining Structure under Existing Bridge Abutments.

Repair and rehabilitation of existing retaining structure.

## **ADVANTAGES OF SOIL NAILING**

**Economic Advantage:** 10% to 30% saving in cost when compared to an Anchored Diaphragm Wall.

**Simple & Light Construction Equipment:** Drilling Ring for nail installation, Guns for shotcrete application

**Adaptability to Site Conditions:** In heterogeneous ground where boulder or hard rocks may be encountered.

**Space:** Soil nailing provides an obstruction free working space which can result in considerable reduction in construction time for basement works and tunnel construction.

**Structure Stability:** Soil nailing use large number of nails, so failure of any one nail may not be determine to the structure stability.

## **COMPONENTS OF THE SYSTEM**

## **LIMITATION OF THE SYSTEM**

- It requires cuts which can stand unsupported for depths of about 1 to 2 m at least for a few hours prior to shotcreting & nailing. Otherwise a pretreatment such as grouting may be necessary to stabilize the face.
- Soil nail walls are not well-suited where large amounts of groundwater seep into the excavation because of the requirement to maintain a temporary unsupported excavation face.
- Construction of soil nail walls requires specialized and experienced contractors.

## **UNIT-5–GROUTING & SOIL CONFINEMENT SYSTEMS**

### **SYLLABUS: GROUTING**

Grouting – Objectives, Grouting Materials, Types of Grouts – Applications, Grouting methods, Concept of confinement – Gabion Walls, Crib Walls, Sand Bags

### **COURSE OUTCOMES:**

Student will be able to enumerate the concepts of soil confinement systems.

### **LEARNING MATERIAL**

#### **GROUTING:**

Grouting is defined as the injection of fluidized materials into voids of the ground or spaces between the ground and adjacent structure under pressure.

The main objective of grouting is to produce a stronger, denser, and/or less permeable soil or rock.

#### **Categories of Grouting:**

Grouting techniques classified according to the method used to introduce the grout into the ground. However other criteria could be used to differentiate grouting methods, such as type of grout material injected, layout of injection points and the sequence of construction.

The basic categories of grouting are

**Penetration Grouting:** It describes the process of filling joints or fractures in rock or pore spaces in soil with a grout without disturbing the formation. More Specifically, Permeation grouting refers to the replacement of water in voids between soil particles with a grout fluid at low injection pressure so as to prevent fracture.

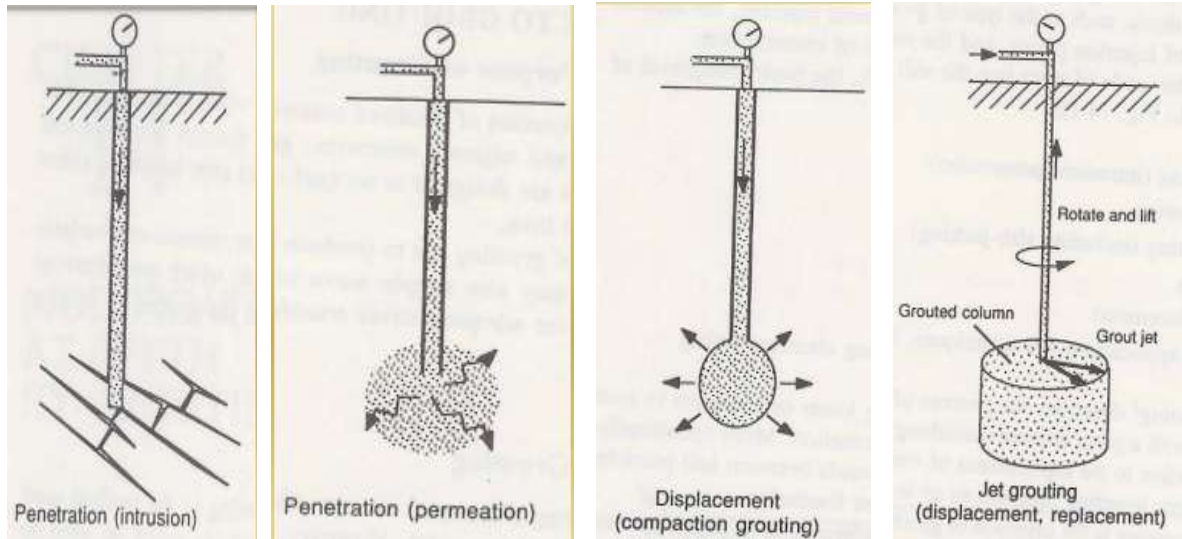

**Displacement Grouting:** It is the injection of grout into a formation in such a manner as to move the formation; it may be controlled, as in compaction grouting or uncontrolled, as in high pressure soil or rock grouting which leads to splitting of the ground, also called *hydro-fracture*.

**Compaction grouting:** A very stiff mortar is injected into loose soils, forming grout bulbs which displace and densify the surrounding ground without penetrating the soil pores. With slightly more fluid grout, thick fissures rather than bulbs may form; this is sometimes termed as *Squeeze Grouting*.

Compaction grouting may be employed for lifting and levelling of heavy structures. A special application is *slab jacking (mud jacking)*, where grout is injected under a concrete slab in order to raise it to a specified grade.

This grout can also be used for filling voids, and special terms have evolved for the grouting behind the lining of tunnels as *Backpack grouting or Prestress Grouting* that involves simultaneous injection of grout through a multipoint system into the space between the tunnel lining and the rock.

**Jet Grouting:** It is a technique where high speed water jets emanating from a drill bit cut into alluvial soils, as the drill bit is withdrawn, grout is pumped through horizontal nozzles and mixes with or displaces the soil. The original foundation material is thus replaced with a stronger or

more impermeable grout soil mixture. Jet grouting may be used to form cut off walls or to form deep foundation similar to ground augur piles

**Electro-grouting:** It is a term used for promoting electrochemical hardening during electro-osmosis by adding chemicals such as calcium chloride, at the anode. Under the influence of the electric field, these chemicals permeate the ground, flowing in the direction of the cathode, while the anode becomes a grout injection pipe.

Depending upon the stabiliser used, grouting techniques can be classified as under.

In this stabilisers are introduced by injection into the soil. As the grouting is always done under pressure, the stabilisers with high viscosity are suitable only for the soils with high permeability. This method is not suitable for stabilising clays because of their very low permeability.

The grouting method is costlier as compared with direct blending methods. The method is suitable for stabilising buried zones of relatively limited extent, such as previous stratum below a dam. The method is used to improve the soil that cannot be disturbed. An area close to an existing building can be stabilised by the method.

### **Types of Grouting:**

1. **Cement Grouting:** A cement grout consists of a mixture of cement and water. If the hole drilled in the soil is smooth, the water cement ratio is kept low. Sometimes, chemicals are added to grout to increase its fluidity so that it can be injected into the soil. Mostly suitable for stabilising rocks like fissures, gravel and coarse sand.
2. **Clay Grouting:** In this method, the grout used is composed of a very fine grained soil and water. The bentonite clay readily adsorbs water on its surface. The viscosity, strength and flow characteristics of the grout can be adjusted according to site conditions. Suitable for stabilising sandy soils. Clay cement grout and clay chemical grout are mixing of cement and chemicals to clay and bentonite respectively which is suitable for stabilising medium and fine sands.
3. **Chemical Grouting:** The grout used consists of a solution of sodium silicate in water,

known as water glass. The solution consists both free sodium hydroxide and colloidal silicic acid. An insoluble silica gel is formed. As the reaction is slow, calcium chloride is generally added to accelerate the reaction and suitable for medium and fine sands.

4. **Chrome lignin Grouting:** The grout used is made of lignosulphates and a hexavalent chromium compound. When it is combined with an acid, the chromium ion changes valence and thereby oxidises the lignosulphates into a gel. Can be used for fine sand and coarse silt.
5. **Polymer grouting:** Different types of polymers can be used for stabilising fine sands and silts.
6. **Bituminous Grouting:** Sandy and silty soils have been grouted successfully using emulsified asphalt. Slow setting emulsions are generally used as these can travel a large distance into the stratum.

### **Confinement Systems:**

Cellular confinement systems (CCS)—also known as geocells—are widely used in construction for erosion control, soil stabilization on flat ground and steep slopes, channel protection, and structural reinforcement for load support and earth retention.

A Cellular Confinement System when infilled with compacted soil creates a new composite entity that possesses enhanced mechanical and geotechnical properties. When the soil contained within a CCS is subjected to pressure, as in the case of a load support application, it causes lateral stresses on perimeter cell walls. The 3D zone of confinement reduces the lateral movement of soil particles while vertical loading on the contained infill results in high lateral stress and resistance on the cell-soil interface. This increases the shear strength of the confined soil, which:

- Creates a stiff mattress or slab to distribute the load over a wider area
- Reduces punching of soft soil
- Increases shear resistance and bearing capacity
- Decreases deformation

Confinement from adjacent cells provides additional resistance against the loaded cell through

passive resistance, while lateral expansion of the infill is restricted by high hoop strength. Compaction is maintained by the confinement, resulting in long-term reinforcement.

On site, the geocell sections are fastened together and placed directly on the subsoil's surface or on a geotextile filter placed on the subgrade surface and propped open in an accordion-like fashion with an external stretcher assembly. The sections expand to an area of several tens of meters and consist of hundreds of individual cells, depending on the section and cell size. They are then filled with various infill materials, such as soil, sand, aggregate or recycled materials and then compacted using vibratory compactors. Surface layers may be of asphalt or unbound gravel materials.

### **Applications:**

- Roadway load support
- Steep soil slope and channel protection
- Earth retention
- Reservoirs and landfills

### **Gabion walls**

Gabion walls are constructed by stacking and tying wire cages filled with trap rock or native stone on top of one another. They can have a continuous batter (gently sloping) or be stepped back (terraced) with each successively higher course.

This is a good application where the retaining wall needs to allow high amounts of water to pass through it, as in the case of riverbank stabilization. It is important to use a filter fabric with the gabion to keep adjacent soil from flowing into or through the cages along with the water. As relatively flexible structures, they are useful in situations where movement might be anticipated. Vegetation can be re-established around the gabions and can soften the visible edges allowing them to blend into the surrounding landscape. For local roads, they are a preferred low-cost retaining structure.

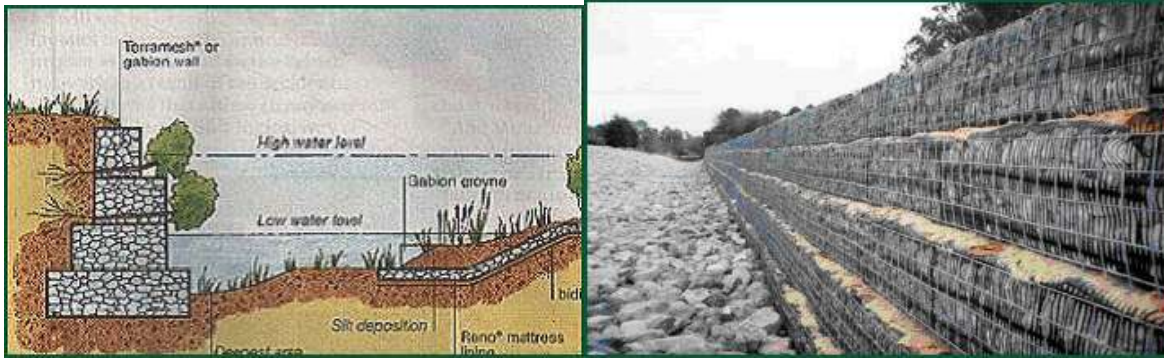

## **Crib walls**

Crib walls have been made of various materials including wood, concrete and even plastic. The cribs are made of interlocking headers and stretchers that are stacked like the walls of a log cabin. Crib walls are usually quite large and can be out of scale and character with the surrounding landscape. In addition, heavy construction equipment is required to lay the courses, possibly impacting sensitive areas. It can be used for moderate heights of 4m to 6m.

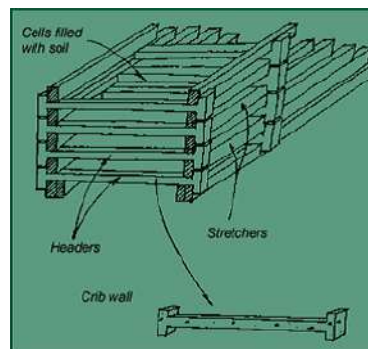



## GEOSYNTHETICS

**Objective:** To know about Geosynthetics

**Syllabus:** Geosynthetics

Geotextiles – Types, functions, properties and applications; Geo-grids & Geomembranes - properties and application

**Outcomes:**

Student will be able to explain the types and functions of geo-synthetics.

### LEARNING MATERIAL

**GEOSYNTHETICS:** Geosynthetics can be defined as planar products manufactured from polymeric material, which are used with soil, rock, or other geotechnical engineering-related material as an integral part of a manmade project, structure, or system (ASTM, 1995). Geosynthetics are widely used in many geotechnical, environmental, and hydraulic applications related to groundwater quality and control. One of the most common examples is the use of geotextile filters in trench (i.e., French) drains. Base and cover liner systems for modern landfills also make extensive use of geosynthetics with the main purpose of minimizing the potential for groundwater contamination. Furthermore, the use of geosynthetics is rapidly increasing in applications related directly to groundwater control. This is the case of high density polyethylene (HDPE) vertical barrier systems, which can be used instead of traditional soil-bentonite cut-off walls in projects involving groundwater remediation and control. The geosynthetics market is strong and rapidly increasing due to the continued use of geosynthetics in well-established applications and, particularly, due to the increasing number of new applications that make use of these products.

**MATERIALS USED FOR GEOSYNTHETICS:**

- Polyamide
- Polyester
- Polyethylene-LDPE,LLDPE,HDPE
- Polypropylene
- Poly vinyl chloride
- Ethylene copolymer bitumen
- Chlorinated polyethylene

PROPERTIES OF GEOSYNTHETICS: Material & fiber properties - temperature & water content

- Geometrical aspects - field boundary conditions, method of execution, width & length, thickness, mass per unit area.
- Mechanical properties - interface friction, fatigue resistance, creep resistance, tear strength, abrasion resistance, seam strength and other.
- Hydraulic properties - filtration & drainage requirements.
- Durability or chemical properties - abrasion resistance & UV resistance.

FAMILIES OF GEOSYNTHETICS:

- Geotextiles
- Geogrids
- Geonets
- Geomembranes
- Geosynthetic clay liners
- Geopipes
- Geocomposites.

### **Functions of Geosynthetics in Civil Engineering and Construction Works**

- Soil reinforcement structure
- Basal reinforcement to support the soil reinforcement structure
- Separation between the in-situ soil and the imported soil to avoid mixing and reducing mechanical performance
- Filtration behind all hydraulic structures
- Drainage control at the top 8 m to collect any seepage water coming from the other side of the embankment to avoid contamination on the structural fill
- Erosion control blanket to protect the slope at the top and avoid erosion.

These functions include:

- Separation: The geosynthetic, placed between two dissimilar materials, maintains the

integrity and functionality of the two materials. It may also involve providing long-term stress relief. Key design properties to perform this function include those used to characterize the survivability of the geosynthetic during installation.

- Filtration: The geosynthetic allows liquid flow across its plane, while retaining fine particles on its upstream side. Key design properties to fulfill this function include the geosynthetic permittivity (cross-plane hydraulic conductivity per unit thickness) and measures of the geosynthetic pore-size distribution (e.g. apparent opening size).
- Reinforcement: The geosynthetic develops tensile forces intended to maintain or improve the stability of the soil-geosynthetic composite. A key design property to carry out this function is the geosynthetic tensile strength.
- Stiffening: The geosynthetic develops tensile forces intended to control the deformations in the soil-geosynthetic composite. Key design properties to accomplish this function include those used to quantify the stiffness of the soil-geosynthetic composite.
- Drainage: The geosynthetic allows liquid (or gas) flow within the plane of its structure. A key design property to quantify this function is the geosynthetic transmissivity (in-plane hydraulic conductivity integrated over thickness).

While comparatively less common in roadway applications, additional geosynthetic functions include:

- Hydraulic/Gas Barrier: The geosynthetic minimizes the cross-plane flow, providing containment of liquids or gasses. Key design properties to fulfill this function include those used to characterize the long-term durability of the geosynthetic material.
- Protection: The geosynthetic provides a cushion above or below other material (e.g. a geomembrane) in order to minimize damage during placement of overlying materials. Key design properties to quantify this function include those used to characterize the puncture resistance of the geosynthetic material.

**GEOTEXTILES:** They are indeed textiles in the traditional sense, but consist of synthetic fibers rather than natural ones such as cotton, wool or silk. Thus biodegradation is not a

problem. They are made into a flexible, porous fabric by standard weaving machinery or are matted together in a random, or nonwoven, manner

### **Woven or Knitted Geotextiles**

### **Non-woven Geotextiles**

FUNCTIONS: Separation, Reinforcement, Filtration, Drainage, Liquid barrier (when impregnated).

Design Considerations: Determine critical function Filtration, Reinforcement, Separation or Drainage

- If Filtration → FOS
- If Reinforcement → Tensile strength and Modulus
- If Separation → Survivability

Consider long-term performance

APPLICATIONS:

#### SEPARATION

#### REINFORCEMENT

#### DRAINAGE AND FILTRATION

GEOGRIDS: Geogrids are plastics formed into a very open, grid like configuration i.e. they have large apertures. Geogrids are either stretched in one or two directions for improved physical properties or made on weaving machinery by unique methods. Used

primarily as reinforcement of unstable soil and waste masses. Geogrids constitute a category of geosynthetics designed preliminary to fulfill a reinforcement function. Geogrids have a uniformly distributed array of apertures between their longitudinal and transverse elements. The apertures allow direct contact between soil particles on either side of the installed sheet, thereby increasing the interaction between the geogrid and the backfill soil. Geogrids are composed of polypropylene, polyethylene, polyester, or coated polyester. They are formed by several different methods. The coated polyester geogrids are typically woven or knitted. Coating is generally performed using PVC or acrylics to protect the filaments from construction damage and to maintain the grid structure. The polypropylene geogrids are either extruded or punched sheet drawn, and polyethylene geogrids are exclusively punched sheet drawn.

Uniaxial Geogrid

Biaxial Geogrid

Woven or Welded Geogrid

Design Considerations:

- Consider tensile modulus and strength
- Mechanical interlock with granular fills
- Damage during construction.

Applications:

**GEOMEMBRANES:** The materials themselves are "impervious" thin sheets of rubber or plastic material used primarily for linings and covers of liquid- or solid-storage or disposal facilities. Thus the primary function is always as a liquid or vapour barrier. Geomembranes are flexible, polymeric sheets that have very low hydraulic conductivity (typically less than 10–11 cm/sec) and, consequently, are used as liquid or vapor barriers. The most common types of geomembranes are high density polyethylene (HDPE), very flexible polyethylene (VFPE), polyvinyl chloride (PVC), flexible polypropylene (fPP) and reinforced chlorosulfonated polyethylene (CSPE). Figure 37.8 shows a number of geomembranes currently available in the geosynthetics market. Polyethylene is the type of geomembrane

most commonly used in landfill applications for base and cover liner systems. This is primarily because of its high chemical resistance and durability. Specifically, high-density polyethylene (HDPE) is typically used in base liner systems. This material is somewhat rigid but generally has good physical properties and can withstand large stresses often imposed on the geomembrane during construction.

#### DESIGN CONSIDERATIONS:

- Leakage rates are determined by Quality Control
- Consider compatibility with retained liquid or waste
- Consider Geomembrane as potential slip-surface on slopes
- Consider exposure to long-term environmental agents of weathering (sunlight, air, burrowing rodents) .

#### APPLICATIONS:

Seepage barrier

Installation of Geomembranes

#### APPLICATION OF GEOSYNTHETICS

Geotextiles and geogrids are widely used to reinforce soil masses in the design of retaining

walls and slopes. In these Mechanically Stabilized Earth (MSE) applications, horizontal layers of the geosynthetics are sandwiched between compacted layers of fill during construction. Lateral spreading of the soil mass is resisted by shearing along the soil–geosynthetic interface and the development of tensile stresses within the reinforcing layers. Internal stability also requires that the geosynthetic layers provide tensile anchorage against potential slope failures by extending into the stable soil mass. The principal parameters in design are the tensile strength and stiffness of the geosynthetic, and the soil–geosynthetic interface shear and bond resistance. Horizontal layers of geosynthetics are also used as basal reinforcements for embankments constructed over soft foundation soils. Basal reinforcement provides additional short-term stability and greatly aids constructability in these situations. Tensile stresses develop due to membrane action in the centre of the basal reinforcement due to undrained deformations of the soil. These stresses transfer through interface shear tractions into both the overlying embankment fill and underlying soft soil improving coherence in the side slopes and redistributing the forces transferred to the underlying clay. The use of geotextiles to separate the soil sub grade from the overlying aggregate (unpaved) road base or railway ballast. rely on tensile stiffness and strength properties of the geosynthetics. The geotextile allows drainage but prevents intrusion of aggregate into a softer underlying material while preventing the pumping of fine particles from the sub grade into the ballast. Geotextiles are frequently used as filter fabrics in subsurface drainage and erosion control applications. Geosynthetic materials are routinely used for subsurface drainage; these include edge/fin drains behind earth retaining walls and prefabricated vertical drains used to accelerate the consolidation of low permeability clays.